



**Project Report
FCRC-PR 99-02**

**FIRE PERFORMANCE
OF FLOORS
AND FLOOR
COVERINGS**

FCRC Project 2 B-1
FIRE PERFORMANCE OF MATERIALS

Fire Code Research Reform Program
December 1999

Important Notice

This Report has been prepared for work commissioned by Fire Code Reform Centre Limited and has been released for information only.

The statements and conclusions of the Report are those of the author(s) and do not necessarily reflect the views of Fire Code Reform Centre Limited, its Board of Directors or Members.

Neither the authors, Fire Code Reform Centre Limited, nor the organisations and individuals that have contributed, financially or otherwise, to production of this document warrant or make any representation whatsoever regarding its use.

Background

The Fire Code Reform Research Program is funded by voluntary contributions from regulatory authorities, research organisations and industry participants.

Project 2 of the Program required investigation of the fire performance of materials used extensively in building construction and currently controlled by regulations. The objectives were to confirm the need for regulatory control and identify the necessary levels of fire performance required from the materials, taking into account the different occupancy and fire conditions that could apply and the likely existence of other required fire safety system components.

This Final Report of Stage "B1" of the Project related to Floors and Floor Coverings were prepared by CSIRO–Division of Building, Construction & Engineering, Delhi Road North Ryde NSW 2113 at the conclusion of its work as principal consultant.

Acknowledgements

Since inception of the Fire Code Reform Research Program in 1994 the Australian Building Codes Board has been its principal financial contributor. Substantial funds have also been provided by Forest and Wood Products Research and Development Corporation and generous contributions have been received from a number of industrial and financial entities and individual donors.

The Board and management of Fire Code Reform Centre Ltd acknowledge with sincere thanks receipt of these financial contributions. The company also acknowledges the permission of CSIRO, Division of Building, Construction and Engineering to re-produce and publish this document.

Comments

Comments on the content or other aspects of this document are always welcome and should be addressed to:- Fire Code Reform Centre Limited, Suite 1201, 12th Floor, 66 King Street, Sydney, NSW 2000, Australia. Tel: +61 (2) 9262 4358 Fax: +61 (2) 9262 4255

FIRE PERFORMANCE OF FLOORS AND FLOOR COVERINGS

Final Report

Fire Code Reform Centre

PROJECT 2

STAGE B-1

December 1999

**FIRE PERFORMANCE OF FLOORS
AND FLOOR COVERINGS**

Final Report

Fire Code Reform Centre

PROJECT 2

STAGE B-1

December 1999

PREPARED BY:

J M Blackmore and M A Delichatsios
CSIRO Fire Science and Technology Laboratory

for

Fire Code Reform Centre Ltd

CONTENTS

Acknowledgements:.....	4
1 Introduction.....	5
2 Review of Current BCA Practice.....	5
2.1 Objectives, Functional Statements and Performance Requirements.....	5
2.2 Deemed-to-satisfy.....	6
3 Review of tests.....	7
3.1 Chosen test methods.....	7
3.2 Reasons for selection.....	8
4 Technical approach.....	9
5 Experimental program and results.....	9
5.1 Test matrix.....	9
5.2 Experimental set-up.....	11
5.3 Results.....	12
6 Analysis of experimental data.....	14
6.1 Aim of analysis.....	14
6.2 Comparison of empirical regulatory measures for consistency in material classification:.....	14
6.3 Comparison of parameters for fire spread and fire growth:.....	15
6.4 Comparison of smoke yield in cone with smoke index in EFH:.....	19
6.5 Effects of reduced air and alternative backings:.....	20
7 Selection of test.....	22
7.1 Flame spread and fire growth criteria.....	22
8 Performance of floor coverings in buildings.....	23
8.1 Selection of fire scenarios.....	23
8.2 Analysis of fire scenarios.....	24
8.3 Quantification:.....	25
9 Recommendations for change to the BCA.....	26
10 Conclusions.....	28
References.....	29
Appendix A - Background.....	A1
Appendix B - BCA Clauses that control floorings and floor coverings.....	B1
Appendix C - Test Method Descriptions.....	C1
Appendix D - Observations and data from Early Fire Hazard Test.....	D1
Appendix E - Data From Flooring Radiant Panel Tests.....	E1
Appendix F - FCRC Project 2 Stage B Cone Tests.....	F1
Appendix G - Data from Previous Experiments.....	G1
Appendix H - Critical Heat Flux from Ignition Times.....	H1
Appendix I - Mass Loss and Specific Extinction Area.....	I1
Appendix J - Early Fire Hazard Tests.....	J1
Appendix K - Smoke Characterisation in EFH and Cone Calorimeter for Wall and Ceiling Linings and Floor and Floor Covering Materials.....	K1

Acknowledgements:

We gratefully acknowledge the cooperation of the Woolmark Company in making data from the Comparative Assessment of the Performance of Various Fire Tests for Floor Coverings freely available for use in the current project. The comparative assessment was conducted in 1998 by CSIRO Fire Science and Technology Laboratory (N.A.McArthur, G.P.Bradbury, P.A.Bowditch, J.E.Leonard) for the Woolmark Company.

We also thank the following staff of the CSIRO Fire Science and Technology Laboratory for their contribution:

Craig Brescianini
Russell Collins
Glen Whittaker
Neville McArthur
Justin Leonard
Nathan White
Glen Bradbury
Paul Bowditch

1 Introduction

The potential for floor coverings (including covering materials on stairs) to contribute to fire growth and spread has long been recognised [1,2,3]. To this end the use of floor coverings is controlled by building regulations, which set criteria and call up a variety of tests in their attempts to provide an appropriate measure of performance. A wide variety of tests have been developed, but there is no international agreement on which test is the most suitable for regulatory control of floor coverings. While the flooring radiant panel test has gained the most acceptance internationally, it is not currently used as a control by Australian building regulations. Our local test is Australian Standard AS 1530.3, known as the Early Fire Hazard Test. This test, originally developed to test wall linings, has generally served Australia well but some deficiencies and the vertical orientation of the specimen makes it unsuitable to assess coverings which melt, and certain floor coverings that are known to present a fire hazard have passed the test. There is need to find a more suitable test or methodology.

Fire Code Reform Project 2A addressed the principles behind regulatory controls on wall and ceiling linings, the suitability of tests used to characterise material performance and the application of expected performance to different building categories [4]. Its output was recommendations for change to the Building Code of Australia (BCA). The main recommendations of Project 2A are to introduce the ISO Room Corner Test as a regulatory requirement, in parallel with the Cone Calorimeter or the EFH test. These last two tests can be used to establish extreme conditions (loosely speaking, very flammable or not very flammable). For the intermediate cases, the ISO Room Test should be performed. Discussions in the Project 2A report on the need to control fire properties of linings, key factors that influence the level of control, categories of buildings where controls might vary and principles for assessing the necessary levels of control apply equally to this project, Project 2B-1. For more detail see Appendix A.

This project aims to provide quasi-performance-based recommendations to characterise the fire hazard for floors and floor coverings. The project encompasses three objectives:

Objective 1: to compare the Cone Calorimeter, EFH, LIFT apparatus and Radiant Panel tests and propose the test best suited for regulatory purposes

Objective 2: to assess the potential risks associated with combustible flooring and floor covering materials at locations within different functional areas and occupancy classes in buildings

Objective 3: to suggest regulatory requirements to be specified within the BCA.

2 Review of Current BCA Practice

2.1 Objectives, Functional Statements and Performance Requirements

Details of current BCA controls on floor coverings are given in Appendix B.

For each BCA Section, Objectives, Functional Statements and Performance Requirements are listed. In summary, the objectives address the safety of building occupants, facilitation of emergency service activities, avoidance of spread of fire between buildings and property protection, in the sense of physical damage to the building caused by structural failure as a result of fire. In addition, precautions must be taken to safeguard occupants from illness or injury while evacuating a building in an emergency. The objectives are restated in the form of more detailed performance requirements (CP2 and CP4), which provide guidance on the classes of and locations within buildings that need to be considered and give an indication of the material properties that need to be controlled. In selecting suitable tests, it is important to note that CP4 requires materials and assemblies to “resist the spread of fire to limit the generation of smoke and heat and any toxic gases likely to be produced”. The performance statements will be taken into account in the selection of the test methods and their application to buildings. Toxicity, which is not addressed in the deemed-to-satisfy provisions of the BCA, is not addressed specifically by this project.

2.2 Deemed-to-satisfy

Current BCA requirements for flooring materials and floor coverings (see Specification C1.10)

<i>BCA building class</i>	<i>Fire-isolated exits</i>	<i>Specific areas</i>	<i>Other areas, including public corridors</i>
Class 2 – apartments	0,2,nc	9,8/5,- (sou)	9,8/5,-
Class 3 – hotels & boarding houses	0,2,nc	9,8/5,- (sou)	9,8/5,-
Class 3 – accommodation for the aged, disabled & children	0,2,nc	9,8/5,- (sou)	9,8/5,-
Class 5 – office buildings	0,2,nc	9,8/5,-	9,8/5,-
Class 6 – shops	0,2,nc	9,8/5,-	9,8/5,-
		0,5 (stairways etc – see Spec D1.12)	
Class 7 – car parks	0,2,nc	9,8/5,-	9,8/5,-
Class 7 & 8 – warehouses & factories	0,2,nc	9,8/5,-	9,8/5,-
Class 9a – health care buildings	0,2,nc	3,5/0,6 (patient care area)	9,8/5,-
Class 9b – theatres, halls etc	0,2,nc	7,5 (auditorium -	9,8/5,-

		unsprinklered)	
Class 9b – swimming or ice skating	0,2,nc	9,8 (auditorium - unsprinklered)	9,8/5,-
Class 9b – indoor sports or multi-purpose	0,2,nc	8,7 (auditorium - unsprinklered)	9,8/5,-
Class 9b – schools	0,2,nc	7,5 (auditorium - unsprinklered)	9,8/5,-

Interpretation:

0,5 Spread-of-flame index 0, Smoke-developed index 5

0,2,nc Spread-of-flame index 1, Smoke-developed index 2, maximum thickness of 1mm for combustible materials

9,8/5,- Spread-of-flame index 9, Smoke-developed index 8 *or* Spread-of-flame index 5, no requirement for Smoke-developed index

3 Review of tests

The final report on FCRC Project 2A – Fire Performance of Wall and Ceiling Linings, gives a detailed description of the need for control of lining materials (Chapter 2), key factors to be taken into account (Chapter 3) and principles for control (Chapter 5). The conclusion to Chapter 5 is that in all locations in all buildings, whether sprinklered or not, the contribution of linings should be considered for:

- 1 time to reach untenable conditions; and
- 2 potential for rapid flame spread.

Untenable conditions are reached if either the heat from the fire is excessive or the smoke layer descends below an acceptable level.

The material properties that will control the potential hazard of flooring materials and floor coverings are therefore:

- Potential to spread fire – horizontally and upward (on stairs);
- Contribution to fire growth (heat release); and
- Smoke generated.

Test methods are considered in the light of their ability to assess these parameters.

3.1 Chosen test methods

Test methods for floor coverings considered in this project are:

1. Early Fire Hazard Test (AS 1530.3)
2. Flooring Radiant Panel Test (ASTM E648, ISO 9239.1)
3. Cone Calorimeter (ASTM E1354, ISO 5660)
4. Hot Nut Test (BS 4790)
5. Methenamine Pill Test (AS 2111.18)
6. 10 m Corridor Test (CSIRO FSTL)
7. Room Fire Tests (ISO 9705)
8. Danish Floorings test for fire and smoke generation (NT Fire 007)

9. LIFT Apparatus (used by IMO for floor coverings).

From these tests the following were chosen for comparison in this project:

- Early Fire Hazard Test (EFH)
- Cone Calorimeter
- Flooring radiant panel (FRP)
- 10 m Corridor Test (for determining performance of floor coverings in enclosures)

A brief description and illustrative sketch of each of the selected tests is given in Appendix C. Further details are given in Appendix J.

3.2 Reasons for selection

The Hot Nut test and the Methenamine Pill test give an indication of how a floor covering will respond to a small point ignition source (as described in the name of the test). They do not demonstrate performance in the presence of other larger heat sources, a limitation that makes them inappropriate for regulatory control of the use of floor coverings in buildings of Class 2-9. These tests are required by the US Consumer Products Safety Commission, to control carpets in all buildings including houses (Class 1 buildings). The control applies to any carpet material that is available on the USA market. It might be worthwhile to consider controls for Class 1 buildings in the BCA, either by using these tests or by selecting appropriate levels in the Flooring Radiant Panel test or the Cone Calorimeter (the tests selected for Class 2-9 buildings).

NT Fire 007 test for fire and smoke generation is a wind-aided floor covering flame spread test that seems very comprehensive including smoke, but unfortunately it is not available or recognised internationally.

LIFT is an appropriate test for floor coverings as it measures lateral flame spread, which is also evaluated by the flooring radiant panel. It is in use by the International Maritime Organization (IMO) for the assessment of flame spread on deck coverings. Because of the vertical orientation of the specimen its use is limited to those materials that do not melt copiously. If the specimen or veneer melts, burns and drips off, it fails the test under IMO regulations. Such control is appropriate where very strict controls are necessary, as in high-speed craft. For these reasons the LIFT apparatus has not been included in the test program.

FRP measures lateral flame spread on a horizontally mounted specimen. The inclined radiant panel simulates a typical heat flux in a room fire. The horizontal orientation of the specimen avoids the problems experienced by LIFT and EFH with specimens that melt. The test is the subject of an ISO standard and is the most internationally accepted test for floor coverings.

The 10 m Corridor Test is a large-scale test that gives an indication of the comparative performance of floor coverings in one particular building enclosure. The data it provides is not suitable for fire engineering calculations, or in assessing the performance of floor coverings in enclosures with different geometries.

EFH was chosen because it is the current Australian test for floor coverings. The remaining tests each provide appropriate, if not sufficient data, are all internationally

recognised and are the subject of ISO Standards. These tests are available within Australia.

4 Technical approach

A wide range of flooring materials and floor coverings (wool carpet, polypropylene carpet, nylon carpet, vinyl tiles) were tested and compared in the chosen tests. Materials were selected to supplement results from the previous tests [5] and maximise the range of test parameters. Tests were conducted using different backing materials and different restraints (with and without mesh in the EFH) so that the effects could be explored. The performance with different backing materials can be used to illustrate changes in performance that might be expected with different backing on a manufactured floor covering, different underlay or different substrate. In addition to the standard measurements, temperature histories at the surface of the floor covering were recorded in some of the tests in the cone and EFH in order to show that results from these two tests are consistent. Finally, performance evaluations based on small-scale tests were compared with floor covering performance in a full-scale corridor test.

Using the test data, comparisons of similar parameters were made. Test results were analysed to:

- 1 compare current regulatory measures for consistency;
- 2 correlate similar parameters in the three test methods for fire spread and fire growth; and
- 3 correlate similar parameters for smoke.

Using these comparisons, appropriate test parameters were selected for regulation and/or input to fire engineering.

For building categories that correspond to those derived in Project 2 Stage A, the influence of floor coverings on the development of fires in various locations within buildings was assessed by consideration of various fire scenarios and recommendations in terms of the chosen test parameters made for amendment to the BCA.

5 Experimental program and results

5.1 Test matrix

Based on the proposed technical approach, the following test matrix was selected. All EFH and FRP tests were run at North Ryde and all Cone tests were run at Highett.

Table 1 – Test Matrix

<i>Material</i>	<i>Backing</i>	<i>EFH</i>	<i>FRP</i>	<i>Cone</i>
W2b	A	Av	2x	C
W2b	B	2x	Av	
N9	A	Av	2x	C
N9	B		Av	
RF1	A	2x	2x	C
RF1	B			
P14	A	Av	2x	

P14	B	2x	Av	
N20	A	2x	2x	
N20	B	2x	2x	C

Explanation:

Materials:

- W2b – Wool carpet
- N9 – Highly flammable nylon carpet
- RF1 – Smooth vinyl flooring
- P14 – Polypropylene carpet
- N20 – Nylon carpet

Backings:

- A Cement sheet (conductive material)
- B Calcium silicate board (insulating material)

Tests:

- EFH – early fire hazard test
- FRP – flooring radiant panel test
- Cone – cone calorimeter
- 2x – EFH and FRP tests were run twice (ie 1 repeat)
- Av – test results available from earlier experimental program
- C – Cone tests were run according to Cone test matrix (see below)

Table 2 - Cone Test Matrix

Material	<i>Test A Air – time to ignition</i>	<i>Test B Air – After ignition</i>	<i>Test C Nitrogen Pyrolysis</i>
<i>Heat flux - kW/m²</i>			
10	☑		
15	✓	✓	✓
25	✓		
35	✓	✓	✓
50	✓		
60	☑		

- ☑ If ignition did not occur at 10 kW/m², additional test were run at 60 kW/ m²

Surface temperatures were recorded with one thermocouple in centre of each EFH specimen and Cone specimen. No thermocouple was used in the FRP. EFH specimens were fixed using edge frame. The presence/absence of retaining mesh was recorded. Cone specimens were glued to the backing sheet; no mesh was used. All test samples (including Cone samples) were conditioned as for EFH (see AS1530.3).

5.2 Experimental set-up

Early Fire Hazard

Tests were carried out in accordance with AS1530.3. The specimens were conditioned for 24 hours, or in accordance with AS1530.3. A thin wire restraining mesh is specified by Standards Australia for materials that might bulge or melt during the test. No restraining mesh was used for one wool carpet (this specimen bulged towards the ignition source during the test) and one vinyl floor covering. Restraining mesh was used on all other specimens. The ignition source was applied to the surface gases in accordance with the standard, and the test was terminated two minutes after ignition in accordance with the Standard procedure.

Surface temperatures were measured using a standard “K” type bead thermocouple. For carpet specimens the thermocouple was tucked into the mesh level with the surface of the carpet. For vinyl flooring, a small incision was made in the surface of the vinyl and the thermocouple was tucked just beneath the surface and secured with glue.

All tests were recorded on video. Observations on the behaviour of the specimens were noted during the test. The observation sheets are given in Appendix D.

Flooring Radiant Panel

The tests were conducted in accordance with ASTM E648. Specimens were conditioned as for AS1530.3.

Cone Calorimeter

Test A – Ignition Tests (see Table 2)

These tests were carried out with a ‘K’ type bead thermocouple placed on the surface of the specimen. Intake air was atmospheric (20.95% oxygen). Tests were completed upon specimen ignition.

2 or 3 replicates of each of the 4 specimens (see Table 1) were carried out at 25, 35 and 10 kW/m² or 60 kW/m². Tests at 60 kW/m² were to be carried out only if specimens did not ignite at 10 kW/m². Wool Carpet (W2B) was tested at 10 kW/m² but it did not ignite, so all remaining tests were done at 60 kW/m².

Data from tests includes temperature rise versus time to ignition and ignition time only. The use of a surface thermocouple may have affected the mass of the specimen at low mass loss rates (just after ignition).

Test B – Burning experiments in air (see Table 2)

Intake air was atmospheric (20.95% oxygen). Tests were completed in accordance with the AS/NZ standard, which in each case was upon specimens reaching the specified mass loss criteria.

Replicates of each of the 4 specimens were carried out at 15 and 35 kW/m².

Cone calorimeter measurements were used to calculate Heat Release Rate, Effective Heat of Combustion, Specific Extinction Area, Mass Loss and CO/CO₂ production. Additional tests were done at 35 kW/m² with a ‘K’ type thermocouple placed on the surface of the specimen purely for observation of the effects of the thermocouple on mass loss rates.

Test C

In these experiments the supply gas stream to the Cone Calorimeter was pure nitrogen. Tests were completed upon specimens reaching the mass loss criteria as per the AS/NZ standard of 150g/m²/s as averaged over a 1 minute period.

Replicates of each of the 4 specimens was carried out at 15 and 35 kW/m².

Cone calorimeter measurements were used to calculate Specific Extinction Area, Mass Loss and CO/CO₂ production. Other calculations could not be done due to the absence of oxygen in the intake air.

5.3 Results

EFH

Observations and data from the Early Fire Hazard tests are given in Appendix D. Time to ignition from these tests and previous tests is shown in Figure 1. The figure shows differences in measurements taken in different apparatus and at different times. The late time to ignition for W2b-1 compared to W2b-2 is due to the presence of the restraining screen. It can be seen that in these experiments ignition times for the same materials in different EFH apparatus are similar. For details of previous experiments see Appendix G. In addition to the standard EFH indices, flame spread downwards was recorded at 2 minutes after ignition. Direct data from the radiometer, smoke obscuration and surface temperature histories are plotted.

FRP

Data from the Radiant Flooring Panel tests are given in Appendix E. Data includes the distance and time at which flame spread stopped, together with the radiant heat flux at that point.

Cone

Data from the Cone Calorimeter are given in Appendix F. Details of experimental procedures and data recorded are given in Section 5.2, Experimental set-up.

Results from previous experiments

Limited data from previous experiments in EFH, FRP and Cone Calorimeter are given in Appendix G.

Figure 1 - EFH: Time to Ignition

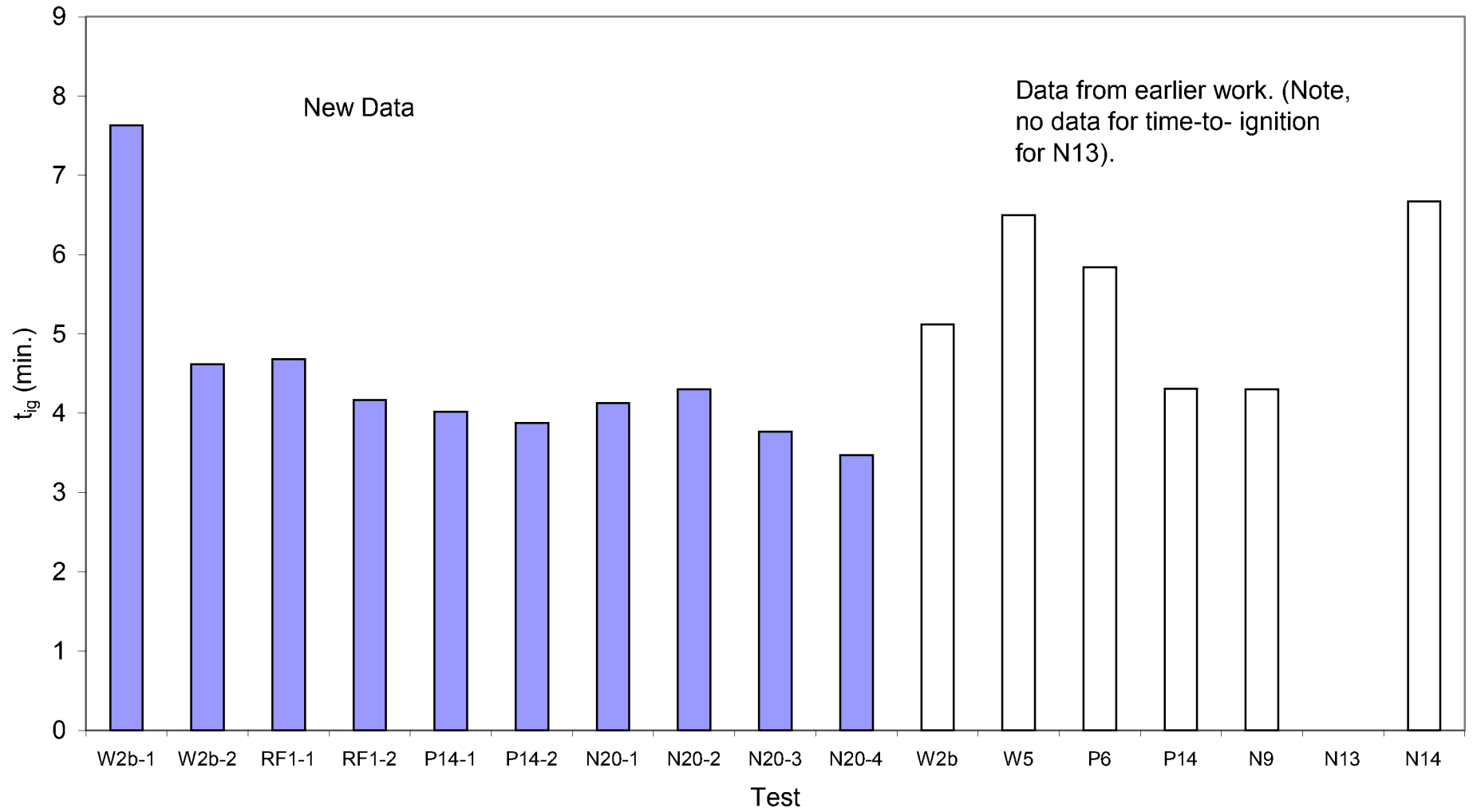

6 Analysis of experimental data

6.1 Aim of analysis

The selected tests measure various aspects of a material's potential for fire spread and fire growth (in the form of how much heat is generated) and smoke generation. The Early Fire Hazard test results are reported in the form of indices that are related to ignition (Ignitability Index), upward fire spread (Spread of Flame Index), fire growth (Heat Evolved Index) and smoke production (Smoke Developed Index) (see Appendix J). The flooring radiant panel provides the critical heat flux at which horizontal spread stops (see Appendix C). The cone calorimeter measures time to ignition, heat released as a function of time and smoke generated in terms of optical density.

It is difficult to correlate parameters (for example, indices and properties) deduced from measurements in the selected tests. For example, the critical heat flux in the cone is calculated from ignition time at different levels of irradiance, and is not assisted by radiation from burning material. The critical heat flux of the flooring radiant panel (that is defined as the heat flux at which flame spread stops) is affected by the contribution of conductive heat from the flame front.

Test results from the three different experiments were analysed to:

- 1 compare current regulatory measures for consistency in material classification; and
- 2 correlate similar parameters in the three test methods, for fire spread and fire growth;
- 3 correlate similar parameters for smoke; and
- 4 assess the effects of reduced oxygen and alternative backings.

This Chapter addresses the above issues in detail, by using the extensive experimental results of this program.

6.2 Comparison of empirical regulatory measures for consistency in material classification:

Currently, regulators use the critical heat flux in the FRP (USA, Europe) and the Spread of Flame Index in the EFH (Australia) to characterise performance of floor coverings [ref NFPA, BCA]. We compare these measures in Figure 2 for consistency between regulatory regimes.

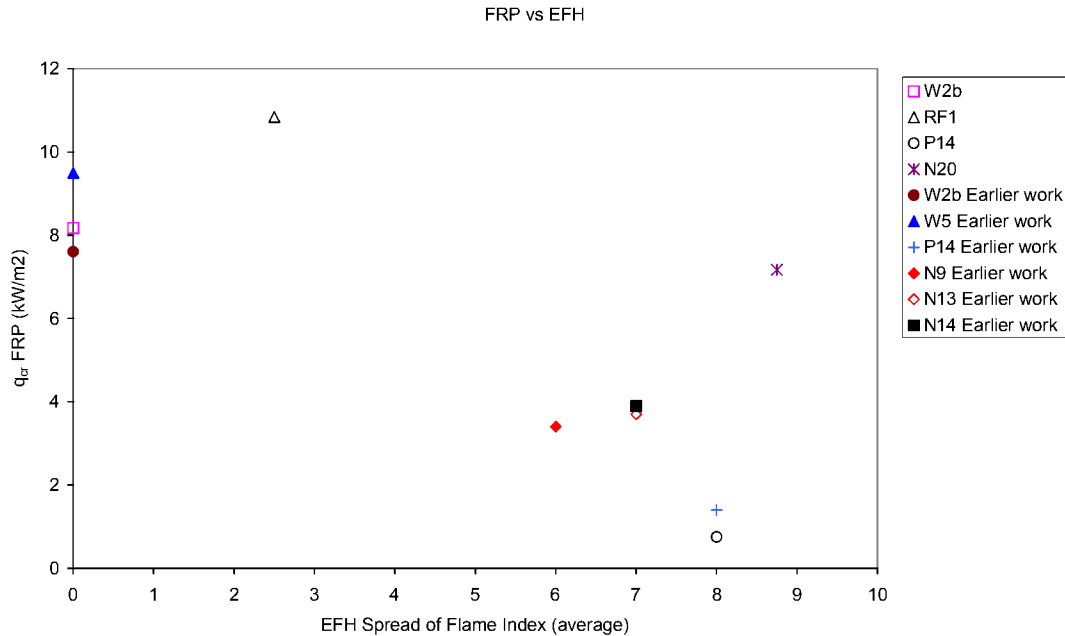

Figure 2. Comparison of FRP critical heat flux with EFH spread of flame index

Note that high values of EFH spread of flame index indicate a bigger hazard, whereas high values of critical heat flux in the FRP apparatus indicate less hazardous material. For “good” materials (those with a low spread of flame index and high critical heat flux), there is partial correlation (see W2b, RF1). The correlation is not good for all materials. Some materials have a high flame spread index (such as N20 and P14) but can have either low critical heat flux (P14) or high critical heat flux (N20). This discrepancy shows that the EFH may unnecessarily penalise materials that could be used safely on horizontal surfaces. One may conclude that the EFH should not be used to characterise horizontal flame spread. History shows this is hardly surprising, since the EFH test was developed to overcome the limitations of horizontal flame spread apparatus (BS 476.7) in characterising upward flame spread on wall linings [6].

6.3 Comparison of parameters for fire spread and fire growth:

6.3.1 Critical heat fluxes

We compare critical heat flux (for fire spread) in the FRP, Cone and EFH (based on an additional measure of downward flame spread which is not included in the current standard test procedure), to see whether the tendency for fire spread (as measured by the FRP) can be measured in either the Cone or by measuring downward flame spread in the EFH.

To this end we compare critical heat flux in the FRP with heat flux at the downward flame spread point in the EFH 2 minutes after ignition (see Figure 3) and critical heat flux in the Cone (the minimum imposed heat flux at which piloted ignition occurs) with critical heat flux in the FRP (see Figure 4). The critical heat flux in the Cone was determined by the x-intercept in the figures in Appendix H.

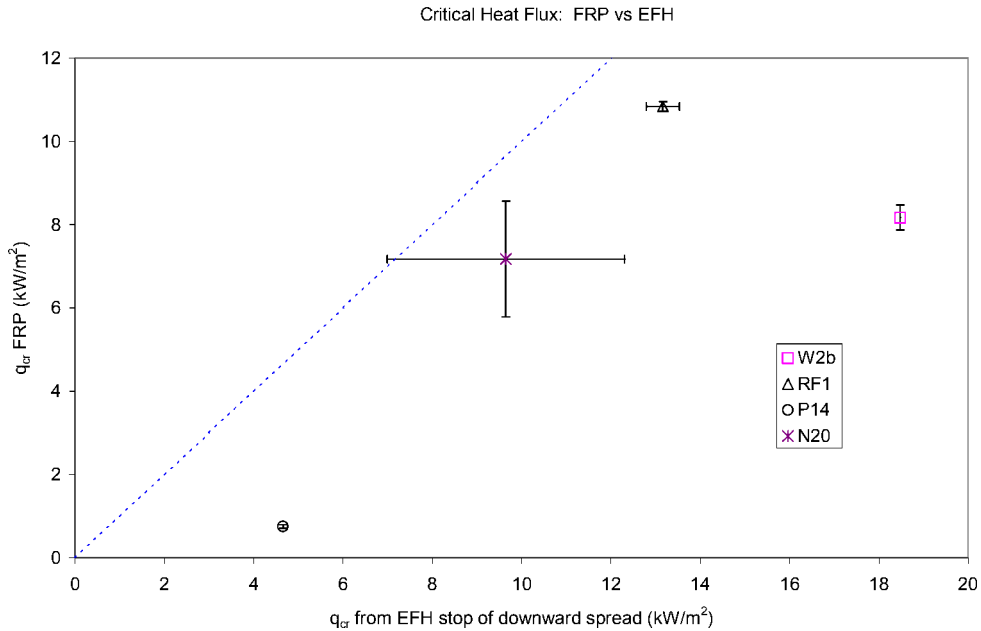

Figure 3. Comparison of critical heat flux in FRP with heat flux at downward-flame-spread point in EFH two minutes after ignition.

The downward spread in the EFH apparatus (see EFH data) was interrupted at 2 minutes after ignition as prescribed in the EFH protocol. The heat flux at this location was calculated using the view factor for the radiant panel. Because the downward spread was interrupted at two minutes, the heat fluxes at the lowest point of flame spread in the EFH are higher than in the FRP apparatus. For the two materials RF1 and N20, the heat fluxes measured in the two apparatus are closer in value because of the relatively short burning time in the FRP and the low heat flux after ignition in the EFH. If downward spread was to continue until it stopped, we expect the heat flux at that point to be equal to the critical heat flux in the FRP. A separate experiment using plywood tested in the EFH, FRP and LIFT apparatus confirms that the critical heat flux is the same. In this experiment downward spread in the EFH was allowed to continue until spread stopped.

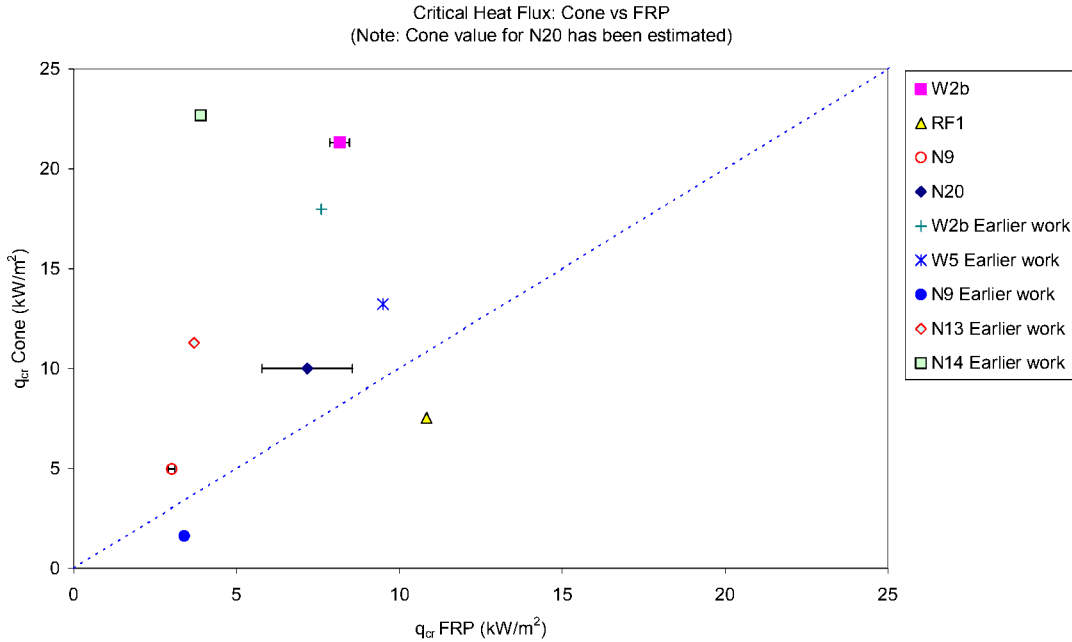

Figure 4. Comparison of critical heat flux in Cone with critical heat flux in FRP.

Figure 4 shows that the critical heat flux in the cone calorimeter (as determined from the ignition times, see Appendix H) does not correlate well with the heat flux in the FRP, but is in general higher. The reason for the higher values in the cone is that ignition and spread in the horizontal spread apparatus is assisted by the conductive heat flux at the flame front [7,8]. We can conclude that the critical heat flux in the cone cannot determine the critical heat flux in the FRP apparatus.

To demonstrate the degree of inconsistency between measurements of critical heat flux in the Cone and heat flux at ignition in the EFH, we include Figure 5.

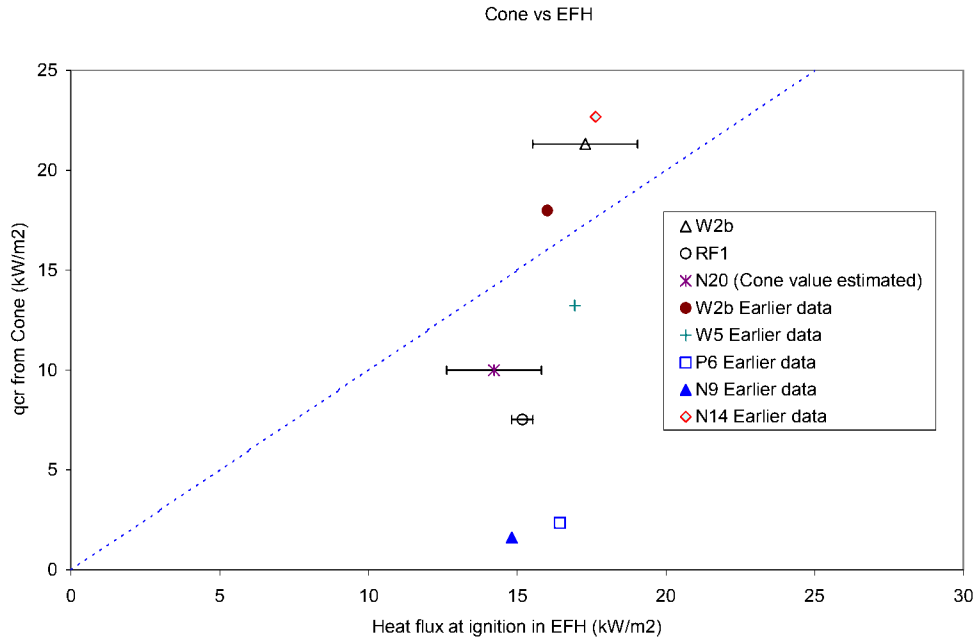

Figure 5. Comparison of critical heat flux in Cone with incident radiation at ignition in the EFH.

One would expect that critical heat flux in the Cone would be close to, but less than, the heat flux at ignition in the EFH apparatus. This is partially supported by Figure 5, although there are discrepancies that may be due to experimental error in the EFH and uncertainties in determining the critical heat flux in the cone (see Appendix H).

6.3.2 Comparison of heat release rates:

For completeness of the correlation, in Figure 6 we compare the heat release rate (HRR) as measured in the Cone with the maximum radiation flux measured in the EFH.

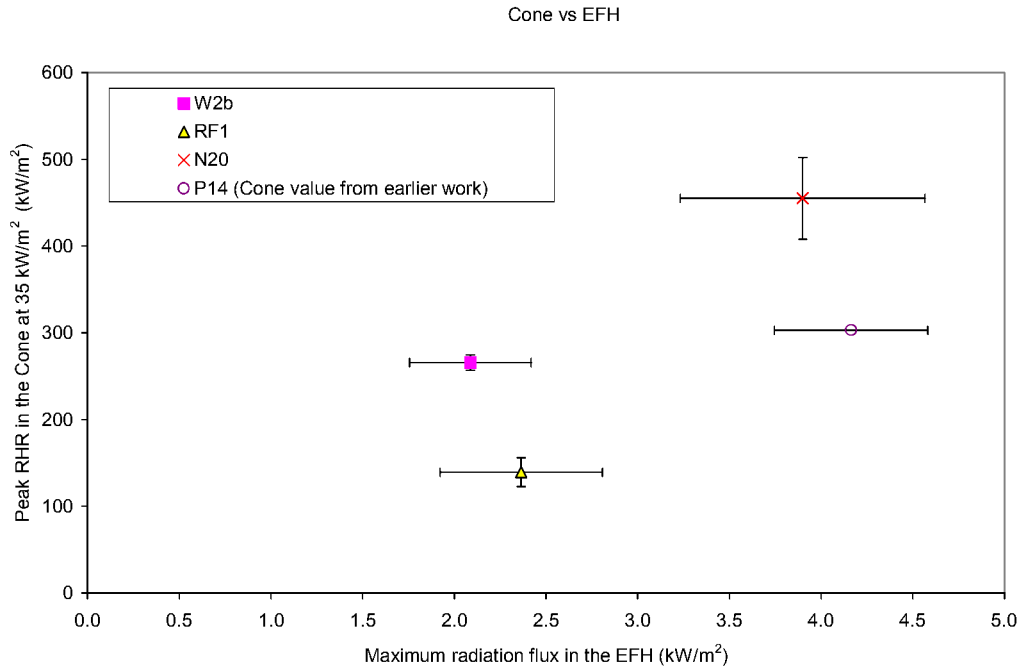

Figure 6. Comparison of peak RHR in the Cone (at irradiance of 35 kW/m²) with maximum radiation flux measured in the EFH.

This figure is quite informative. It shows that there is a good correlation between the radiation measurements in the EFH apparatus and the HRR in the Cone. This result indicates that the most hazardous materials are those that generate high radiation levels. One should note that the EFH apparatus is the only test apparatus in the world that directly measures flame radiation.

6.4 Comparison of smoke yield in cone with smoke index in EFH:

To assist in the selection of a proper smoke measure for regulatory and fire engineering purposes, in Figure 7 we compare smoke yield as measured in the Cone with the Smoke Developed Index of the EFH. The Smoke Developed Index is proportional to the obscuration measured in the EFH exhaust duct. This plot could be useful in comparing new selected levels of smoke control with current BCA practice for floor coverings, despite the lack of scientific basis for current requirements.

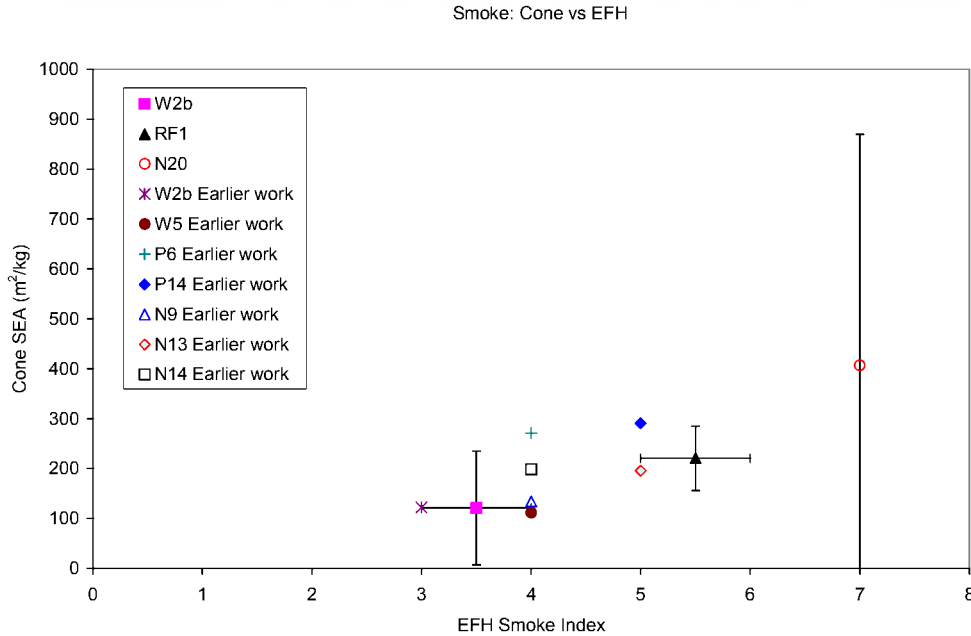

Figure 7. Comparison of smoke yield in cone with smoke index in EFH.

Comparison of Specific Extinction Area (proportional to smoke yield) with the EFH smoke index gives good correlation although the EFH smoke measurement has serious problems because the exhaust rate is not controlled [5]. At least we can judge the selection of the appropriate value of SEA from the cone based on this comparison. For completeness we explain how SEA is related to smoke yield.

The SEA is equal to:

$$\{ \text{extinction coefficient (1/m)} * \text{the flowrate in duct (m}^3/\text{s)} \} / \{ \text{mass loss rate (kg/s)} \}$$

It is related to smoke yield, Y_s , (g/g) by

$$SEA = K_m * Y_s$$

where:

$$K_m = 7.6 \text{ m}^2/\text{g for flaming conditions (small particles)}$$

$$K_m = 4.4 \text{ m}^2/\text{g for smoldering condition (larger particles)}$$

6.5 Effects of reduced air and alternative backings:

Comment on nitrogen pyrolysis experiments

Plots of mass loss rate and smoke yield are given in Appendix I. The objective was to see whether the total smoke yield increases or decreases as oxygen levels are reduced. The figures show that the total smoke yield remains nearly the same, despite the reduction in oxygen. It is true that the mass loss rate without flames (in nitrogen) compared to the

mass loss rate with flames (in air) is much lower, as might be expected. However, the product of the mass loss rate with smoke yield for each material remains nearly the same, independent of the flame conditions. This product represents the smoke production rate (m^2/s), which is the critical parameter to determine the smoke hazard.

Comment on effects of backing material on the measurements

Theoretical discussion

The experimental methods have been designed to provide measurements that can be used for the determination of material properties. These measurements can be affected by the heat losses on the unexposed side of the material. These heat losses depend in turn on the thermal properties of the backing material as well as the thickness of the top and the backing material.

For the same reasons the backing material of a floor covering installation may affect its fire spread and fire growth behaviour.

In the present work, we have examined for illustration two backing materials that behave as thermally thick:

1. Cement sheet having the following thermal properties: conductivity coefficient $k = .32 \text{ W/m K}$, density $\rho = 1000 \text{ kg / m}^3$ and specific heat $C = 840 \text{ J / kg K}$. Its thermal inertia is $(k\rho C)_{\text{cement}} = .37 (\text{kW})^2 / \text{s m}^4 \text{ k}^2$.
2. Calcium silicate sheet having the following thermal properties: conductivity coefficient $k = .095 \text{ W/m K}$, density $\rho = 430 \text{ kg / m}^3$ and specific heat $C = 1500 \text{ J / kg K}$. Its thermal inertia is $(k\rho C)_{\text{calcium silicate}} = .061 (\text{kW})^2 / \text{s m}^4 \text{ k}^2$.

The calcium silicate sheet is used as a good thermal insulator as the property values indicate. For comparison the thermal inertia of one of the floor coverings RF-1 has been calculated from the ignition data (see Appendix H) to be:

$$(k\rho C)_{\text{RF1}} = .56 (\text{kW})^2 / \text{s m}^4 \text{ k}^2 \text{ s}$$

Experimental results

Based on the properties of the backing material, we had expected that their effects on the present measurements would be significant as other work on multiple layers shows [10,11]. However, the experimental results show that these effects are not significant in the present tests, most probably due to the limited number of tests.

Specifically, for the EFH tests differences in indices for the two backing materials are insignificant as the summary of Early Fire Hazard Test results in Appendix D shows for N20 (all present tests), P14 (present and previous tests) and W2B (present and previous tests). Closer examination, however, of the radiation data for N20 (see Figure on Page D13 of Appendix D), shows significant delay in ignition time for the test where the backing material is the cement sheet.

Similarly, for the FRP tests the difference in critical heat flux is not significant as the summary of flooring radiant panel test results in Appendix E shows for N20 (all present tests), P14 (present and previous tests) and W2B (present and previous tests).

Although we can determine the effects of backing material given its thermal properties [8,9], this approach is not practical at present because of the variety of backing materials and floor coverings.

The present experiments and earlier experiments [10,11] have shown that backing in carpets will sometimes change (increase or decrease) the carpet's critical heat flux in the FRP and sometimes it will not change it. The critical heat flux can be determined by a balance of heat input at the flame front from the burner and the flame compared to heat lost by reradiation from the surface and the heat lost by conduction into the solid [8,9]. The backing will affect directly the last component and indirectly the reradiation losses that may increase if the spread is so slow that char is formed on the surface before ignition occurs.

There will be no effect on the critical heat flux if the thermal penetration depth, δ , at the moment that spread stops is less than the carpet thickness, L . In this case the heat conducted into the solid will not be affected by the backing. This relation is expressed as:

$$\delta = \sqrt{\alpha t} \leq L$$

where α is the thermal diffusivity of the carpet $\cong 10^{-7} m^2 / s$, a value that is valid for many common materials [8,9]. The time in the previous relation is the recorder time that flame spread stops.

In the other cases, the backing will change (increase or decrease) the critical heat flux of the carpet depending on the relative values of thermal inertia of the carpet and the backing. Therefore, the carpet and its backing should be tested as a composite material in the various flammability tests or by using an insulated backing material such as calcium silicate board [see also earlier work 10,11]

7 Selection of test

The material properties that control the potential hazard of floor coverings are:

- Potential to spread fire – horizontally and upward (on stairs);
- Contribution to fire growth (heat release); and
- Smoke generated.

Test methods have been considered in the light of their ability to assess these parameters. The present results and analysis lead to the following remarks regarding appropriate test methods for floor coverings.

7.1 Flame spread and fire growth criteria

Based on the analysis in Section 6 we can conclude the following:

1 Figure 2 and the associated discussion (comparison of FRP critical heat flux and EFH Spread of Flame Index) show that the EFH test cannot be used to characterize horizontal flame spread as in floor coverings. The EFH test unnecessarily penalizes materials for floor coverings, see discussion following Figure 2. This is substantiated by

comparison with a full-scale corridor test [ref. McArthur, FSS 5th International Symposium] which shows that EFH cannot always differentiate between the performance of two floor coverings while FRP can. In addition, other previous tests [5] show that it may misrepresent the behaviour for materials that may melt and drip away before ignition occurs in the EFH apparatus.

It follows that the FRP is appropriate for assessing flame spread from floor coverings.

2 Comparison of FRP and Cone results in Figure 3 shows that the Cone cannot be used to determine the critical heat flux as measured in the FRP, see also discussion following Figure 3. It follows that the Cone alone can not replace the FRP apparatus.

3 There are situations (for example, for floor coverings on stairs) where the FRP critical heat flux is not sufficient to assess fire growth because fire spread involves also spread on vertical surfaces. Measurement of heat release such as in the Cone calorimeter is necessary to address this situation (see also discussions on selection of test method for flame spread on vertical surfaces in FCRC Project 2A [4]).

We may conclude that the FRP apparatus and the Cone should be used to characterise fire spread in floor coverings. The FRP is suitable for horizontal surfaces and the Cone is needed where there is any vertical component. [12].

7.2 Smoke generation criteria

Because no smoke measurements are taken in the FRP apparatus, it is necessary to use the Cone results for characterizing smoke generation by deducing smoke yields (in terms of the Specific Extinction Area) and providing appropriate criteria for fire safety.

A correlation of smoke yields with the smoke index in the EFH apparatus (see Figure 7 and following discussion) can guide the selection of appropriate and comparative values for smoke yield criteria as discussed in the following section.

Finally, the present results in reduced oxygen experiments without combustion (see Appendix I) show in general that the total production rate (= mass loss rate times smoke yield) is nearly the same as in the tests with combustion. Thus, experiments in flaming conditions in the cone should be sufficient to characterize the smoke generation rates.

8 Performance of floor coverings in buildings

8.1 Selection of fire scenarios

Fire spread and fire growth can be characterised by

- (a) determining flammability properties of floor coverings from selected tests; and
- (b) assessing the use of floor coverings in buildings in terms of their flammability properties.

To reach compliance with the performance requirements of the BCA, specific fire scenarios are used. In selecting these scenarios we considered the following diagrammatic representation of escape paths within buildings. The sketch can be taken to represent most escape paths from buildings (in some cases components might not be

present). The hazard presented by floor coverings will depend upon the location of the floor covering within the building.

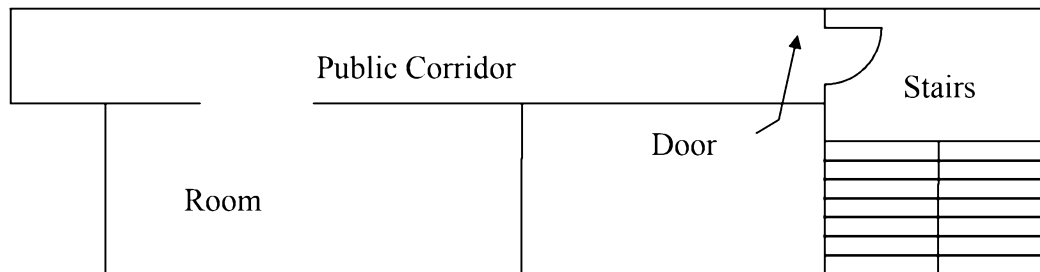

Sketch illustrating building locations

After consideration of various scenarios, including reported fires, four scenarios were considered wherein floor coverings have a critical influence on the fire hazard:

- (a) a non-flashover fire on the room floor
- (b) a near flashover fire in the room
- (c) a flashover fire in the room spreading to the corridor
- (d) a fire on the floor covering of the stairs.

We believe that these scenarios address most of the issues involved in quantifying the fire hazard within the representative arrangement of the sketch. Each scenario is considered with and without sprinklers.

8.2 Analysis of fire scenarios

In this section we consider in detail each of the scenarios listed above to establish which will influence the choice of and level of test parameters recommended for control. We consider smoke generation separately from fire growth and fire spread.

8.2.1 Fire growth and fire spread

- (a) a non-flashover fire on the room floor

In this case we consider a fire generated by the floor covering, without contribution from the hot layer. The fire spread and growth will be slow on a horizontal surface provided there is some general control to guard against very rapid flame spread. This scenario will not influence the choice of parameters.

- (b) a near flashover fire in the room

In this case there will be considerable hot layer radiation. We need to ensure that the floor covering does not ignite and contribute to the size of the fire until the people have evacuated the room. Once ignition occurs, conditions within the room will be too hot for survival. Appropriate levels of control will therefore depend upon the conditions under which people can survive. For fire engineering purposes conservative control could be obtained by ensuring that ignition does not occur until the room has been evacuated.

- (c) a flashover fire in the room spreading to the corridor

In this case spread in the corridor will be slow before flashover occurs, as for (a). By the time the room reaches flashover, it can be assumed that building occupants will have evacuated the corridor. In this case general controls to prevent very rapid flame spread will be sufficient.

(d) a fire on the floor covering of the stairs

In this case we consider any location where the floor has a vertical component, such as stairs, ramps and stepped or sloping auditoria. We must consider upward flame spread, and recommendations of Project 2a are relevant.

8.2.2 *Smoke generation*

(a) a non-flashover fire on the room floor

As above, the fire will be small. There is a possibility that the fire will not be detected, especially if the room is large. In this case a general level of control on smoke spread will ensure that floor coverings do not contribute to a decrease in time to untenable conditions.

(b) a near flashover fire in the room

For this scenario the hot layer radiation could cause the floor covering to produce smoke, even prior to ignition. However, by this time the occupants are expected to have evacuated the room, and the concern is only with smoke spread to other areas of the building.

(c) a flashover fire in the room spreading to the corridor

For smoke, this scenario is similar to (b) above.

(d) a fire on the floor covering of the stairs

This situation is similar to (a) for a small ignition source on the floor, or (b) if ignition is caused by a fire in another room.

8.3 Quantification:

In Chapter 7, use of both the Cone Calorimeter and the FRP were recommended for controls on floor coverings. Both tests are needed in order to quantify flame spread, fire growth and smoke production.

For all floor coverings, the FRP should be used to assess flame spread and the Cone is necessary to assess smoke production.

For stairs, ramps and sloping or stepped floors, rate of heat release and time to ignition in the Cone Calorimeter are also needed to assess fire growth (see Section 7.1).

Fire growth and flame spread on horizontal surfaces

For general control, ignition of the floor covering should not occur until the room has become untenable and the occupants have escaped. Accepted international values [10,11] of critical heat flux in the FRP are:

2.2 kW/m² for areas where occupants are mobile; and

4.5 kW/m² for situations where evacuation is not possible.

These values correspond to ceiling layer temperatures of 185°C and 257°C respectively.

If these values are adopted, the floor coverings will not increase the risk to building occupants.

Smoke generation

For smoke it is recommended that an appropriate control is the product of the specific extinction area and the rate of heat release measured in the Cone. It is suggested that a value of 70,000 using values obtained in the Cone at an exposure of 50kW/m² would be appropriate.

Specific extinction area x heat release rate (HRR) < 70,000 kW / kg (m²/kg x kW/m²)

This value represents an average rate of smoke production between that of wool carpet and that of polypropylene. Justification for this value and smoke characterisation in the EFH and the Cone are given in Appendix K.

The data provided by this method is sufficient to perform an engineering analysis.

Fire growth and flame spread on steps and ramps

All requirements for horizontal surfaces apply.

In addition, upward flame spread must be limited.

We suggest that controls should be equivalent to Material Group b from Fire Code Reform Project 2A, or a characteristic upward (wind assisted) fire spread growth:

$$(\text{HRR})^2 / t_{\text{IGN}} < 10,000 \text{ (kW /m}^2\text{)}^2\text{/s}$$

where HRR and t_{IGN} are measured in the Cone Calorimeter at 50kW/m².

Sprinklers

Where sprinklers are present in a building, the chance of fire growing beyond the initial stages is greatly reduced. If we assume that the sprinklers operate and are effective, the chance of fire growth is eliminated. An assessment of sprinkler performance in Australia between 1886 and 1968 (by Marryatt) showed that sprinkler operation was satisfactory in 99.75% of the 5734 fires reported. In 81,425 fires reported in the U.S. between 1897 and 1969, sprinkler operation was satisfactory in 96.15% of cases [13,14]. We therefore suggest that, in areas where sprinklers are likely to be effective,

- (A) in all situations, the lower value of critical radiant flux will be sufficient to prevent rapid flame spread in the unlikely event of sprinkler failure; and
- (B) there is no need for smoke control.

Since AS2118.1 addresses standard sprinkler systems only (that is, sprinklers that are suitable for spaces with a standard ceiling height), the probability of sprinklers failing to work effectively is much greater in lofty spaces. We therefore suggest that under present sprinkler controls no concession should be made in the deemed-to-satisfy requirements for sprinklers in spaces over 4m high. This is reflected in Table 9.1, where no concession is made for the presence of sprinklers in auditoria.

9 Recommendations for change to the BCA

The justification for recommendations for change to the BCA is given in Section 8.3, Quantification. The following table suggests recommended changes to the various BCA occupancy classes, in buildings with and without sprinklers. In making suggestions, the effectiveness of other fire safety measures has been taken into account. For example, while sprinklers will be effective in suppressing a fire in its early stages in an office building, this is not likely to be the case in a lofty auditorium using a standard sprinkler system.

Table 9.1 Recommendations for control of horizontal spread and smoke control

Building category	Fire-isolated exits		Other areas	
<i>Controls on floor coverings:</i>	<i>FRP Critical Radiant Flux</i>	<i>Cone HRRxSEA at 50kW/m²</i>	<i>FRP Critical Radiant Flux</i>	<i>Cone HRRxSEA at 50kW/m²</i>
Apartments				
unsprinklered	2.2 kW/m ²	70,000	2.2 kW/m ²	70,000
sprinklered	2.2 kW/m ²	70,000	2.2 kW/m ²	none
Hotels & boarding houses				
unsprinklered	2.2 kW/m ²	70,000	2.2 kW/m ²	70,000
sprinklered	2.2 kW/m ²	70,000	2.2 kW/m ²	none
Aged accommodation				
unsprinklered	4.5 kW/m ²	70,000	4.5 kW/m ²	70,000
sprinklered	4.5 kW/m ²	70,000	2.2 kW/m ²	none
Office buildings				
unsprinklered	2.2 kW/m ²	70,000	2.2 kW/m ²	70,000
sprinklered	2.2 kW/m ²	70,000	2.2 kW/m ²	none
Shops				
unsprinklered	2.2 kW/m ²	70,000	2.2 kW/m ²	70,000
sprinklered	2.2 kW/m ²	70,000	2.2 kW/m ²	none
Car parks				
unsprinklered	2.2 kW/m ²	70,000	2.2 kW/m ²	70,000
sprinklered	2.2 kW/m ²	70,000	2.2 kW/m ²	none
Warehouses & factories				
unsprinklered	2.2 kW/m ²	70,000	2.2 kW/m ²	70,000
sprinklered	2.2 kW/m ²	70,000	2.2 kW/m ²	none
Health care buildings - patient care areas				
unsprinklered	4.5 kW/m ²	70,000	4.5 kW/m ²	70,000
sprinklered	4.5 kW/m ²	70,000	2.2 kW/m ²	none
Health care buildings – areas other than patient care areas				
unsprinklered	4.5 kW/m ²	70,000	2.2 kW/m ²	70,000
sprinklered	4.5 kW/m ²	70,000	2.2 kW/m ²	none
Theatres, halls etc - auditoriums				
unsprinklered			2.2 kW/m ²	70,000
sprinklered			2.2 kW/m ²	70,000

Theatres, halls etc – areas other than auditoriums				
unsprinklered	2.2 kW/m ²	70,000	2.2 kW/m ²	70,000
sprinklered	2.2 kW/m ²	70,000	2.2 kW/m ²	none
Schools				
unsprinklered	2.2 kW/m ²	70,000	2.2 kW/m ²	70,000
sprinklered	2.2 kW/m ²	70,000	2.2 kW/m ²	none

Fire growth and flame spread on steps and ramps

Recommendations for additional requirements to control fire growth and flame spread on steps and ramps are given in Section 8.3.

10 Conclusions

Based on a comprehensive research and test program for the evaluation of various test methods and methodologies, the following conclusions have been reached:

- 1 The EFH is not adequate for the assessment of fire performance of floor coverings (see Figure 2 and associated discussion).
- 2 The FRP is a suitable test for flame spread on horizontal surfaces. (see Section 7.1). It does not measure smoke generation.
- 3 The Cone Calorimeter is a suitable test for determining upward flame spread. It can also be used to assess smoke production (see Section 7).
- 4 The critical heat flux can also be measured in the EFH apparatus for non melting materials.
- 5 Recommendations for change to the BCA have been made for different classes of building including auditoriums and health care buildings, with and without sprinklers, in terms of parameters obtained from the chosen tests.
- 6 In buildings with effective sprinklers, less stringent controls on floor coverings are recommended. Further research is needed to realise the full benefits of sprinkler systems.
- 7 Consideration should be given to introducing a general control for floor lining materials used in all classes of building, including Class 1.

References

- 1 Shipp, Martin and Russell, Andrew, Carpet increased severity of fire which claimed four lives – Fire Prevention No 287, March 1996
- 2 A study of the flammability of carpets, Fire prevention No 122
- 3 Ames, S. Colwell, R. and Shaw, K., the Fire Behaviour and Fire Testing of Carpet used as Stair Covering, Interflam '96.
- 4 Dowling, V.P. and Blackmore, J.M., Fire Performance of Wall and Ceiling Linings, Final Report Project 2 Stage A, Fire Code Reform Centre
- 5 McArthur, N.A. , G.P.Bradbury. P.A.Bowditch and J.E. Leonard “Comparative Assessment of the Performance of Various Fire Tests for Floor Coverings” Confidential BCE Doc. 98/131, 1998
- 6 Ferris, J.E. “Test facilities for combustible lining boards”, CEBS Library Unpublished Paper (UP) 45.
- 7 Chen. Y. , Motevalli, V. Tatem. P and Delichatsios M.A. “ Horizontal Flame Spread : Modeling and Experiments” 26th International Symposium on combustion, The Combustion Institute, 1998.
- 8 Brescianini, C, Webb A. and Delichatsios , M.A. “ Time to Ignition in the Early Fire Hazard Test” presented at 1999 Australian Symposium on combustion , Newcastle , Australia 1999.
- 9 Brescianini, C and Delichatsios, M.A. “ Heat Transfer in Multiple Layers: Analytical and Numerical Solutions” Report prepared for FSTL/CSIRO, June 1999.
- 10 Hartzell , L.G. “ Development of a Radiant Panel Test for Flooring Materials” NBSIR 74-495, 1974
- 11 Benjamin, I.A. and Adams C. H. “ Proposed Criteria for Use of the Critical Radiant Flux Test Method” NBSIR 75-950, 1975
- 12 Delichatsios, M.A. and Saito, K., Upward fire spread: Key flammability properties, similarity solutions and flammability indices. Fire Safety Science – Proceedings of the Third International Symposium pp 217 – 226.
- 13 Richardson, J.K., An assessment of the performance of automatic sprinkler systems, SFPE Technology Report 84-2.
- 14 Rohr, K.D., U.S. experience with sprinklers – Who has them, how well do they work. National Fire Protection Association, September 1997.

Background

Aim

Fire Code Reform Project 2 Stage A addressed the principles behind regulatory controls on wall and ceiling linings, the suitability of tests used to characterise material performance and the application of expected performance to different building categories [1]. Its output was recommendations for change to the Building Code of Australia (BCA). The main recommendations of Project 2A are to introduce the ISO Room Corner Test as a regulatory requirement, in parallel with the Cone Calorimeter or the EFH test. These last two tests can be used to establish extreme conditions (loosely speaking, very flammable or not very flammable). For the intermediate cases, the ISO Room Test should be performed. Discussions in the Project 2A report on the need to control fire properties of linings, key factors that influence the level of control, categories of buildings where controls might vary and principles for assessing the necessary levels of control apply equally to this project, Project 2B-1.

This project (Project 2B-1) aims to provide quasi-performance-based recommendations to characterise the fire hazard for floors and floor coverings. For this purpose we set the following three objectives:

- Objective 1: to compare the Cone Calorimeter, EFH, LIFT apparatus and Radiant Panel tests and propose the test best suited for regulatory purposes.
- Objective 2: to assess the potential risks associated with combustible flooring and floor covering materials at locations within different functional areas and occupancy classes in buildings.
- Objective 3: to suggest regulatory requirements to be specified within the BCA.

Need for control

The need to control fire spread from floorings is internationally acknowledged and has resulted in the development of a variety of tests for hazard assessment and approval. Some recent fires illustrate the damage that can result from inappropriate use of floor coverings [1,2,3]. In the first instance, four lives were lost in a fire in a house that had been carpeted with 100% polypropylene-corded carpet. Tests conducted by Fire Research Station (FRS) “clearly demonstrated that a carpet can make some contribution to a well-developed fire” [1]. The second fire [2], in which a mother of four died, was started by young children playing with matches. The carpeting on the stairs and hallway was of acrylic fibre pile with a polypropylene and hessian backing. “While the fire was confined to the hall and stairway, the heat and smoke given off by the burning carpet caused severe damage to the first floor where the mother’s body was found.” The third reference [3] describes three fires in which stair carpet contributed to rapid fire spread.

Key factors

A discussion on key factors which influence the selection of appropriate controls for lining materials was given in Chapter 3 of the final report on Project 2 Stage A [4]. The key factors are the same for floor linings as they are for wall and ceiling linings, and those which need consideration are:

- ignition sources;
- building layout – location of enclosures within buildings;
- enclosure size and geometry;
- ventilation of enclosure;
- enclosure contents;
- occupant activity, mobility and density; and
- the presence of other fire safety systems, such as alarms and sprinklers.

Building categories

A discussion on building categories is given in Chapter 4 of the final report on Project 2 Stage A [4]. The same building categories will be used in this project. Building categories are:

- apartments;
- hotels and boarding houses;
- accommodation for the aged, disabled and children;
- office buildings;
- shops;
- car parks;
- warehouses and factories;
- health care buildings;
- theatres and halls; and
- schools.

General description of tests – their capabilities and shortcomings

In the early 1950's, John Ferris of the Commonwealth Experimental Building Station noted that [5]:

“.. fire tests for combustible linings seem to fall into three categories:

- (1) those tests for which classification of lining boards is in accordance with some fundamental property;....
- (2) those tests which appear to be arbitrary, and which do not seem to simulate practical conditions; and
- (3) those tests which have been devised to simulate some particular phase of the growth of fire, or some particular fire hazard...

It is believed that a true classification of the fire hazard of combustible lining boards will not necessarily result from tests in group 2, as the conditions of test are unrealistic and the absolute and even relative assessment of linings will vary with conditions.

Group 3 tests will be satisfactory to the extent that the simulation of real conditions is complete.

Group 1 tests depend upon proper knowledge of one of the following conditions:

- (a) A strict relationship between the fundamental property of the material and its behaviour as a composite unit.
- (b) Some empirical equation relating the fundamental property of a material and its realistic behaviour as a composite unit.

Unfortunately, in many heat problems and in practically all fire problems, no such simple relationship can be established as is envisaged in the first condition. The second condition has the limitation that any empirical equation which is devised can hold only within the range of experimentation.”

The situation has changed little. Despite a proliferation of small-scale tests, no currently available test measures, independent of scenario, all the fundamental properties needed to predict fire growth. Nor can we fully explain the relationship between the fundamental properties and fire growth. Standard tests such as the ISO Room Fire Test [6] give us a means of assessing hazard related to particular scenarios, but even taking into account the range of large-scale data available internationally it is not possible to interpolate for all situations.

Until tests have been developed that measure the range of fundamental properties needed for performance predictions (can we specify these here?), the best that can be done at present is to examine the available tests and select those that best measure properties suitable for predicting performance in real fires. Empirical evidence can then be used to support predictions of the use of floor coverings in terms of the selected test results.

International trends

ISO is developing a number of Standard test methods for floor coverings that will provide data for mathematical models and other fire engineering purposes. Of particular interest are the Cone Calorimeter [7] and the Reaction to fire test for floorcoverings [8]. Neither of these tests has reached a state of stability and discussions are still taking place on appropriate test parameters. A round robin is currently being conducted to investigate irradiance levels in the Reaction to fire test for floorcoverings. The Fire Code Reform Centre would benefit tremendously if CSIRO FSTL were to participate [9]. Also under consideration by ISO is the application of test results to predict fire performance [10]. Europe (CEN) is following ISO and adopting ISO Reaction to fire tests as they become available. Separate guidance is given for the application of test results.

BCA Clauses that control flooring and floor coverings

OBJECTIVES, FUNCTIONAL STATEMENTS AND PERFORMANCE REQUIREMENTS

Section: C Fire Resistance

Part: C1 Fire Resistance and Stability

Objective

CO1

The Objective of this Section is to-

- (a) safeguard people from illness or injury due to a fire in a building; and
- (b) safeguard occupants from illness or injury while evacuating a building during a fire; and
- (c) facilitate the activities of emergency services personnel; and
- (d) avoid the spread of fire between buildings; and
- (e) protect other property from physical damage caused by structural failure of a building as a result of fire.

Functional Statements

CF1

A building is to be constructed to maintain structural stability during fire to-

- (a) allow occupants time to evacuate safely; and
- (b) allow for fire brigade intervention; and
- (c) avoid damage to other property.

CF2

A building is to be provided with safeguards to prevent fire spread-

- (a) so that occupants have time to evacuate safely without being overcome by the effects of fire; and
- (b) to allow for fire brigade intervention; and
- (c) to sole-occupancy units providing sleeping accommodation; and

Application:

CF2 (c) only applies to a Class 2 or 3 building or Class 4 part.

- (d) to adjoining fire compartments; and
- (e) between buildings.

Performance Requirements

CP2

A building must have elements which will, to the degree necessary, avoid the spread of fire-

- (a) to exits; and
- (b) to sole-occupancy units and public corridors; and

Application:

CP2 (b) only applies to a Class 2 or 3 building or Class 4 part.

- (c) between buildings; and

- (d) in a building,

appropriate to-

- (i) the function or use of the building; and
- (ii) the fire load; and
- (iii) the potential fire intensity; and
- (iv) the fire hazard; and
- (v) the number of storeys in the building; and
- (vi) its proximity to other property; and
- (vii) any active fire safety systems installed in the building; and
- (viii) the size of any fire compartment; and
- (ix) fire brigade intervention; and
- (x) other elements they support; and
- (xi) the evacuation time.

CP4

A material and an assembly must, to the degree necessary, resist the spread of fire to limit the generation of smoke and heat, and any toxic gases likely to be produced, appropriate to-

- (a) the evacuation time; and
- (b) the number, mobility and other characteristics of occupants; and
- (c) the function or use of the building; and
- (d) any active fire safety systems installed in the building.

Section: D Access and Egress

Part: D1 Provision for Escape

Objective

DO1

The Objective of this Section is to-

- (a) provide, as far as is reasonable, people with safe, equitable and dignified access to-
 - (i) a building; and
 - (ii) the services and facilities within a building; and
- (b) safeguard occupants from illness or injury while evacuating in an emergency.

Functional Statements

DF1

A building is to provide, as far as is reasonable-

- (a) safe; and
 - (b) equitable and dignified,
- access for people to the services and facilities within.

Application:

DF1(b), with respect to people with disabilities, only requires special provisions in-

- (a) a Class 3, 5, 6, 8 or 9 building; or
- (b) a Class 7 building other than a Class 7 carpark associated with a Class 2 building; or
- (c) a Class 10a building other than a Class 10a building associated with a Class 1 or 2 building or Class 4 part of a building.

DF2

A building is to be provided with means of evacuation which allow occupants time to evacuate safely without being overcome by the effects of an emergency.

Limitation:

DF2 does not apply to the internal parts of a sole-occupancy unit in a Class 2 or 3 building or Class 4 part.

Performance Requirements

There are no performance statements relevant to Specification D1.12 Clause 2(e) or (m).

DEEMED-TO-SATISFY

Section: C Fire Resistance

Part: C1 Fire Resistance and Stability

Clause: C1.10 Fire Hazard Properties

Materials and assemblies in a Class 2, 3, 5, 6, 7, 8, or 9 building must comply with Specification C1.10.

Specification C1.10 - Early Fire Hazard Indices

Clause:

1 Scope

This Specification sets out requirements in relation to the fire hazard properties of materials, linings and surface finishes in buildings.

2 Class 2 to 9 buildings: General requirements

Except where superseded by Clause 3 or 4, any material or component used in a Class 2, 3, 5, 6, 7, 8, or 9 building must-

- (a) in the case of a sarking-type material, have a Flammability Index not more than 5;
or
- (b) in the case of other materials, have-
 - (i) a Spread-of-Flame Index not more than 9; and
 - (ii) a Smoke-Developed Index not more than 8 if the Spread-of-Flame Index is more than 5; or
- (c) be completely covered on all faces by concrete or masonry not less than 50 mm thick; or
- (d) in the case of a composite member or assembly, be constructed so that when assembled as proposed in a building-
 - (i) any material which does not comply with (a) or (b) is protected on all sides and edges from exposure to the air; and
 - (ii) the member or assembly, when tested in accordance with Specification A2.4, has a Smoke-Developed Index and a Spread-of-Flame Index not exceeding those prescribed in (b); and
 - (iii) the member or assembly retains the protection in position so that it prevents ignition of the material and continues to screen it from access to free air for a period of not less than 10 minutes.

3 Fire-isolated exits

In a fire-isolated stairway, fire-isolated passageway, or fire-isolated ramp in a Class 2 to 9 building-

- (a) a material, other than a sarking-type material used in a ceiling or used as a finish, surface, lining or attachment, must have a-
 - (i) Spread-of-Flame Index of 0; and
 - (ii) Smoke-Developed Index of not more than 2; and
 - (iii) if combustible, be attached directly to a non-combustible substrate and not exceed 1 mm in finished thickness; and
- (b).....

4 Class 2,3 and 9 buildings

A material, other than a sarking-type material must if-

- (a)...
- (b) in a Class 9a building in a patient-care area, it is used as a finish, surface, lining or attachment to a-
 - ...
 - (iii) floor - have a-
 - (A) Spread-of-Flame Index of not more than 3 and a Smoke-Developed Index of not more than 5; or
 - (B) Spread-of-Flame Index of 0 and a Smoke-Developed index of not more than 6; or
- (c) in a Class 9b building not protected by a sprinkler system used as a theatre or public hall, in the auditorium or audience seating area, it is used as a finish, surface, lining or attachment to a-
 - ...
 - (iii) floor - have a Spread-of-Flame Index of not more than 7 and a Smoke-Developed Index of not more than 5, except where the auditorium is used mainly for-
 - (A) indoor swimming or ice skating - have a Spread-of-Flame Index of not more than 9 and a Smoke-Developed Index of not more than 8; or
 - (B) other indoor sports or multi-purpose functions - have a Spread-of-Flame Index of not more than 8 and a Smoke-Developed Index of not more than 7; or

...

5 Materials deemed to comply

A material complies with Clauses 2, 3 or 4 if it is-

- (a) plaster, cement render, concrete, terrazzo, ceramic tile or the like; or
- (b) a fire-protective covering.

6 *Fire-retardant coatings not acceptable*

Paint or fire-retardant coatings must not be used in order to make a substrate comply with a required Spread-of-Flame Index, Smoke-Developed Index or Flammability Index.

7 *Exempted building parts and materials*

The requirements in this Specification for a Spread-of-Flame Index, Smoke-Developed Index or Flammability Index do not apply to-

- ...
(e) materials used for-
- ...
(ii) adhesives; or...
- ...
(f) paint, varnish, lacquer or similar finish, other than nitro-cellulose lacquer; or
- ...
(k) any other material that does not significantly increase the hazards of fire.

Section: D Access and Egress

Part: D1 Provision for Escape

Specification D1.12 Non-required stairways, ramps and escalators

1. *Scope*

This Specification contains the requirements to allow non-required stairways, ramps or escalators to connect any number of storeys in a Class 5 or 6 building. The requirements do not apply in an atrium or outside a building.

2. *Requirements*

An escalator, moving walkway or non-required non-fire-isolated stairway or pedestrian ramp will comply with the requirement of Clause D1.12(b)(iv) if it is constructed as follows:

- ...
(e) when a fire door is closed the floor or any covering over the floor beneath the fire door must not be combustible.
- ...
(m) materials attached to any wall, ceiling or floor within the shaft must have a Spread-of-Flame Index of 0 and a Smoke-Developed Index of not more than 5.

Test Method Descriptions

Early Fire Hazard Test (EFH) – AS 1530.3

Thermal attack	Thermal flux field	Incrementally increasing flux field as a function of time
	Flux level	2.4 – 24.7 kW/m ²
	Ignition source	Gas flame
	Duration of thermal attack	20 min or until 2 min after ignition
	Type of heat source	Premixed gas fired radiant panel
Ventilation	Exhaust flow	Yes
	Fully ventilated	Yes
Geometry sample	Position	Vertical moving towards heat source
	Position thermal attack	710 mm - 175 mm
	Dimensions	600 x 450 mm
Measurements	Time to ignition	
	Radiation intensity at surface	
	Time for increase in radiation of 1.4 kW/m ² after ignition	
	Optical density of exhaust gas	

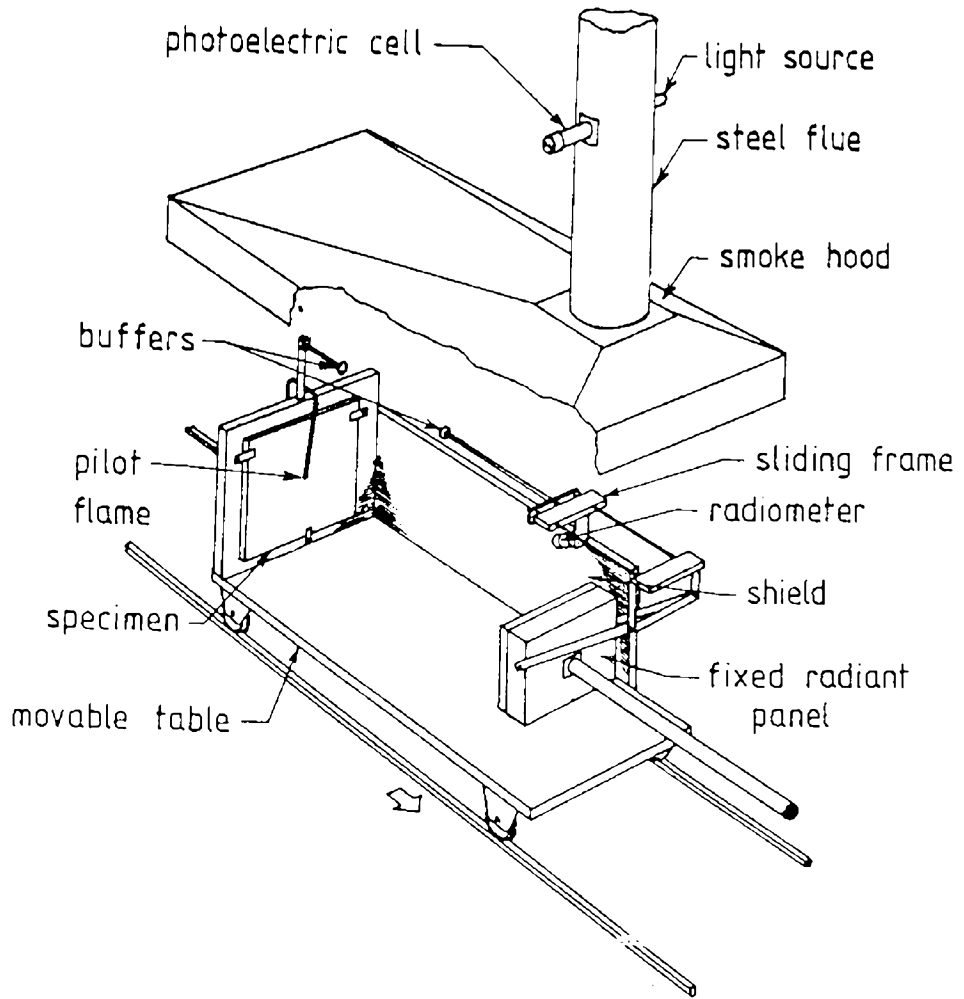

AS 1530.3 TEST APPARATUS

Cone Calorimeter (ISO 5660)

Thermal attack	Thermal flux field	Uniform heat flux
	Flux level	0-100 kW/m ²
	Ignition source	Electric spark plug
	Duration of thermal attack	Max 60 min
	Type of heat source	Electrical conical heater
Ventilation	Exhaust flow	Yes
	Fully ventilated	Yes
Geometry sample	Position	Horizontal/vertical
	Position thermal attack	Horizontal/vertical
	Dimensions	100 x 100 mm
Measurements	Mass loss as a function of time	
	Ignition time	
	Opacity as a function of time	
	Extinction time	

CSIRO Fire Science and Technology Laboratory

ISO 5660-1 Rate of heat release from building products
Cone calorimeter

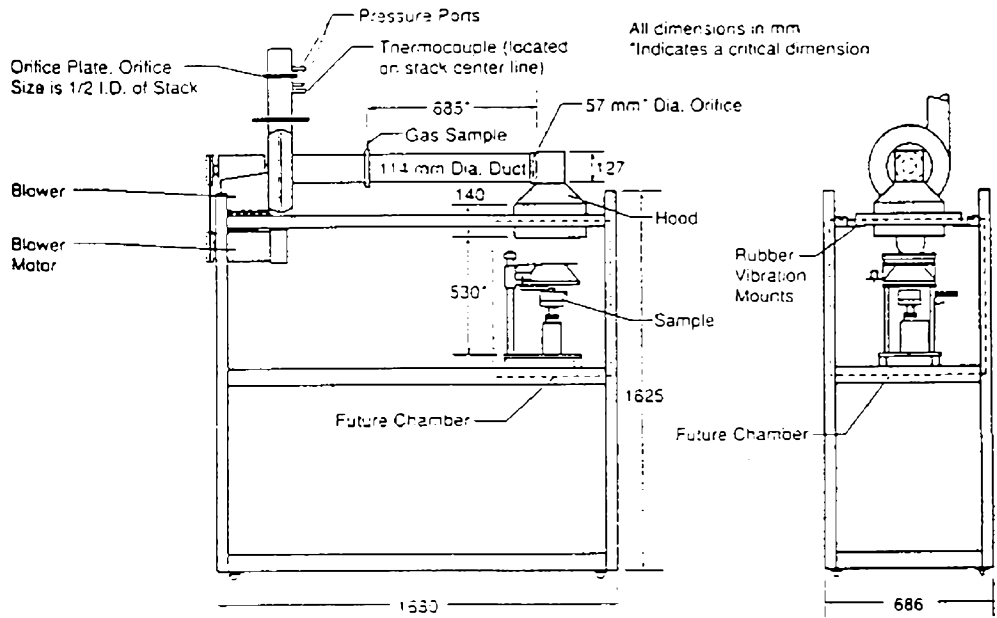

LIFT apparatus (ISO/DTR/5658)

Thermal attack	Thermal flux field	Decreasing flux field from the hot end of the specimen to the end
	Flux level	Hot end 50.5 kW/m ² end of specimen 1.5 kW/m ²
	Ignition source	Gas flame
	Duration of thermal attack	Until flame out or 10 min. without ignition
	Type of heat source	Premixed gas fired radiant panel
Ventilation	Exhaust flow	Yes
	Fully ventilated	Yes
Geometry sample	Position	Vertical
	Position thermal attack	Vertical under 15° with respect to the specimen plane
	Dimensions	155 x 800 mm
Measurements	Flame spread as a function of time	
	Extinction time	

ISO/DTR/5658-3 Lateral ignition and flame spread of building products
a) ignition test

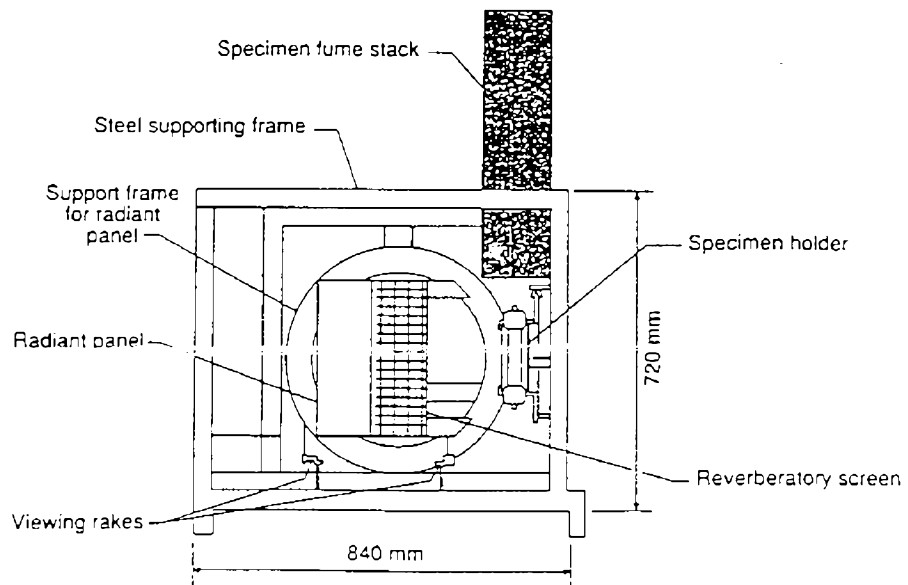
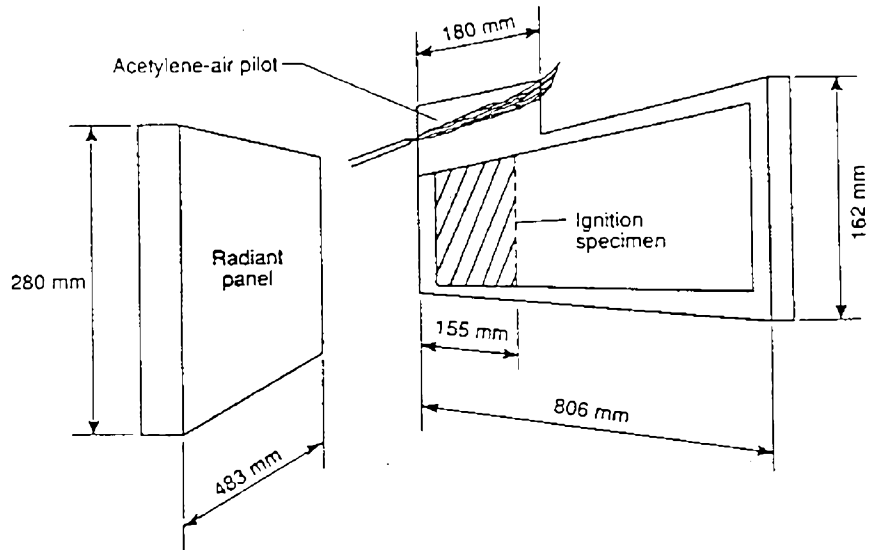

Flooring radiant panel (ISO 9239)

Thermal attack	Thermal flux field	Decreasing flux field from the hot end of the specimen to the end
	Flux level	Hot end 11 kW/m ² End of specimen 1.1 kW/m ²
	Ignition source	Gas flame
	Duration of thermal attack	Until flame out or a prefixed time (eg 30')
	Type of heat source	Premixed gas fired radiant panel
Ventilation	Exhaust flow	Yes
	Fully ventilated	Yes
Geometry sample	Position	Horizontal
	Position thermal attack	30°
	Dimensions	1015 x 200 mm
Measurements	Temperature of combustion gases as a function of time	
	Gas temperature inside box as a function of time	
	Flame spread as a function of time	
	Extinction time	

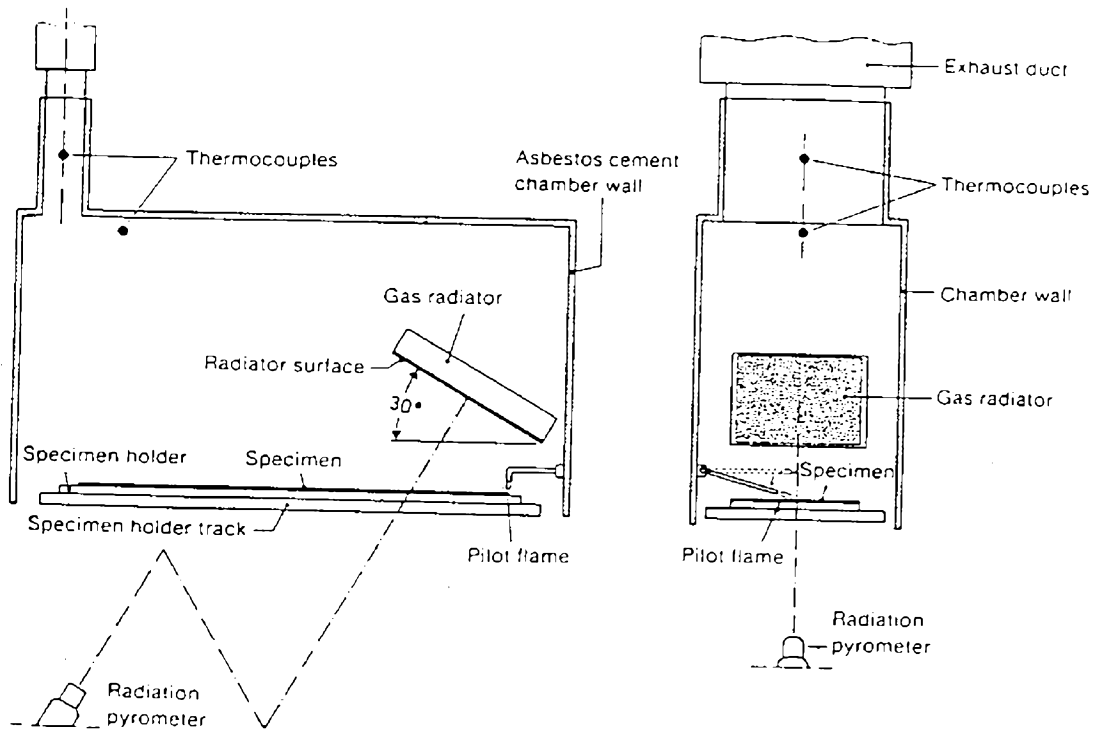

Flooring Radiant Panel

Danish NT Fire 007 Floorings: fire spread and smoke generation

Thermal attack	Thermal flux field	Wood crib
	Flux level	Wood crib
	Ignition source	Crib
	Duration of thermal attack	Burning duration of crib
	Type of heat source	Crib
Ventilation	Exhaust flow	Yes
	Fully ventilated	Yes
Geometry sample	Position	30° to horizontal
	Position thermal attack	Crib in contact
	Dimensions	400 x 1000 mm
Measurements	Flame spread	
	Light absorption	

NT Fire 007 Floorings: fire spread and smoke generation

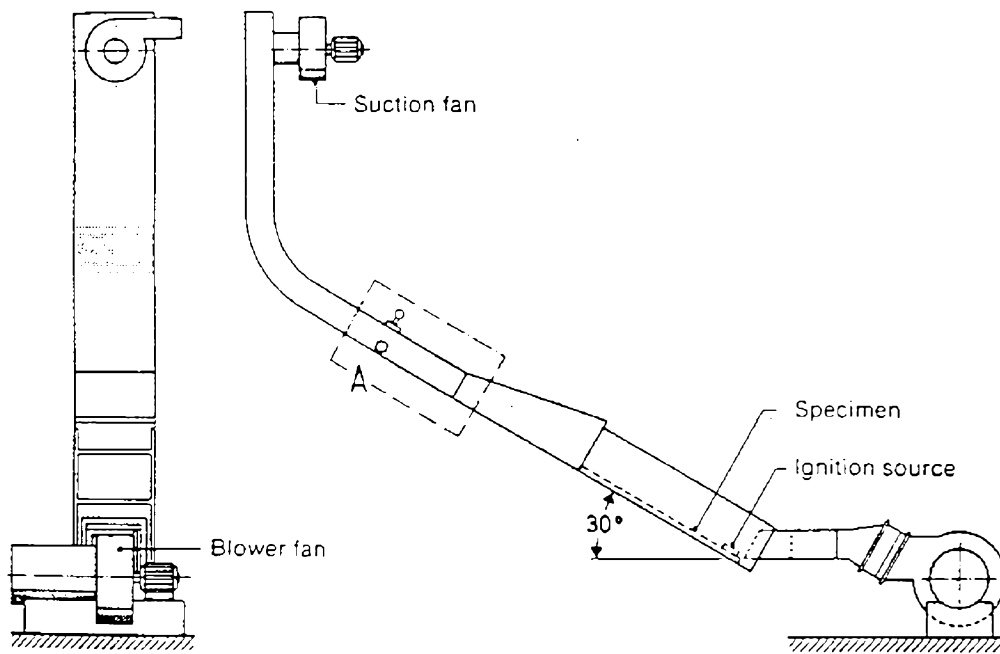

NT Fire 007 Floorings: fire spread and smoke generation

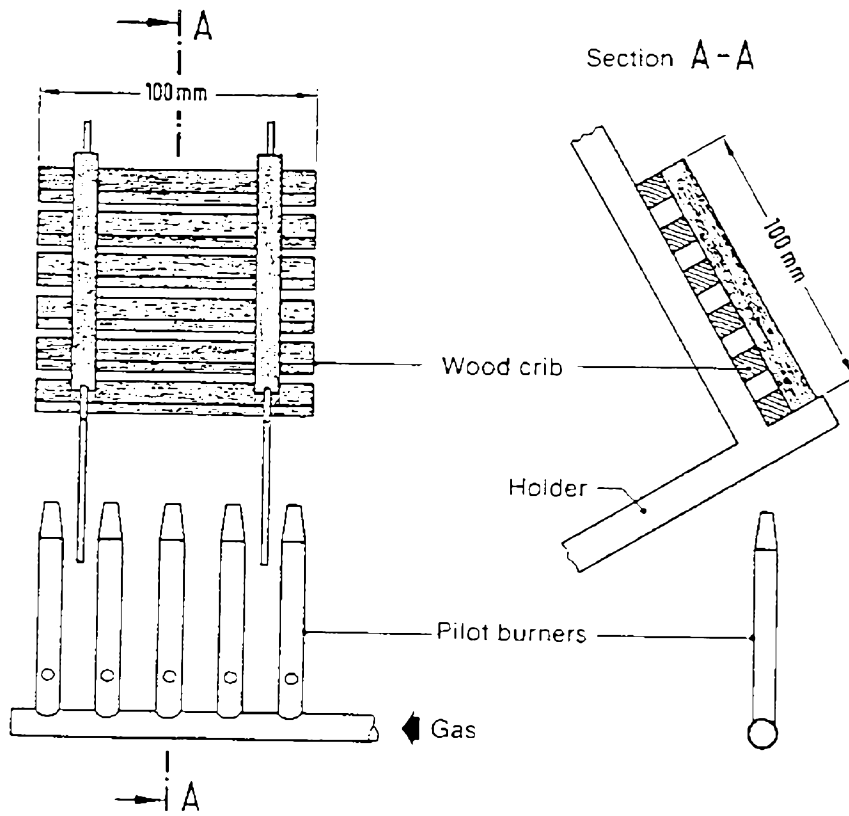

APPENDIX D

Observations and data from Early Fire Hazard Test – AS 1530 Part 3

Summary of Early fire hazard test results, in terms of indices:

<i>AS1530.3 Index Carpet code</i>	<i>Backing CaSi = calcium silicate board Cement = cement sheet</i>	<i>Ignitability range 0 - 20</i>	<i>Spread of flame range 0 - 10</i>	<i>Heat evolved range 0 - 10</i>	<i>Smoke developed range 0 - 10</i>
W2b-1	CaSi	12	0	1	4
W2b-2*	CaSi	15	0	1	3
RF1-1*	Cement	15	5	4	5
RF1-2	Cement	16	0	1	6
P14-1	CaSi	16	8	8	5
P14-2	CaSi	16	8	10	6
N20-1	Cement	16	9	7	7
N20-2	Cement	16	8	7	7
N20-3	CaSi	16	9	8	7
N20-4	CaSi	17	9	8	7
<i>From previous experiments:</i>					
W2B	Cement	15	0	0	3
W5	Cement	13	0	1	4
P6	Cement	14	7	5	4
P14	Cement	16	8	7	5
N9	Cement	16	6	5	4
N13 (guidance test)	Cement	11	7	5	5
N14	Cement	13	7	6	4

* No restraining mesh was used in these experiments

Early Fire Hazard Test Observation Sheets

Test #:	W2b - 1		
Date:	22/6/99		
Operator:	Russell Collins		
Material description:	Wool Carpet		
Method of support:	Screen		
Substrate:	Calcium silicate board		
Thermocouple attachment:	tucked into mesh		
Conditioning:	24 hours		
Video:	Yes ref:		
Time of first smoke:			
Time of discolouration:			
Time of bulging:	No bulging		
Place of first ignition:	Centre		
Smoke spill from hood:	Yes / No / Time		
Test duration (min):	11.1		
Time to ignition (min):	7.63	Ignitibility Index:	12
Spread time (sec):	N/A	Spread of Flame Index:	0
Heat Integral (cm ²):	7.1929	Heat Evolved Index:	1
Smoke Integral (cm ²):	5.381	Smoke Developed Index:	4

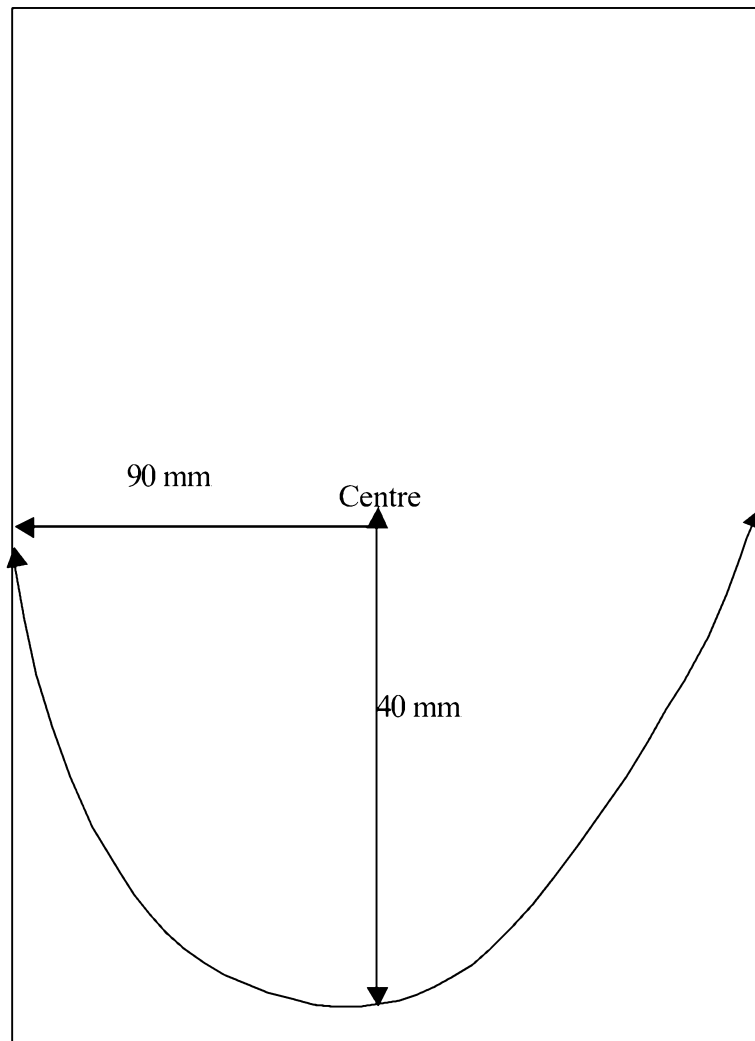

Fire Code Reform Project 2b

Early Fire Hazard Test

Test #:	W2b – 2 (no mesh – ignore results)		
Date:	22/6/99		
Operator:	Russell Collins		
Material description:	Wool Carpet		
Method of support:	No screen		
Substrate:	Calcium silicate board		
Thermocouple attachment:	tucked into mesh		
Conditioning:	24 hours		
Video:	Yes ref:		
Time of first smoke:			
Time of discolouration:			
Time of bulging:	Extensive bulging well before ignition		
Place of first ignition:	Top		
Smoke spill from hood:	Yes / No / Time		
Test duration (min):	8.1		
Time to ignition (min):	4.62	Ignitability Index:	15
Spread time (sec):	N/A	Spread of Flame Index:	0
Heat Integral (cm ²):	4.214	Heat Evolved Index:	1
Smoke Integral (cm ²):	3.307	Smoke Developed Index:	3

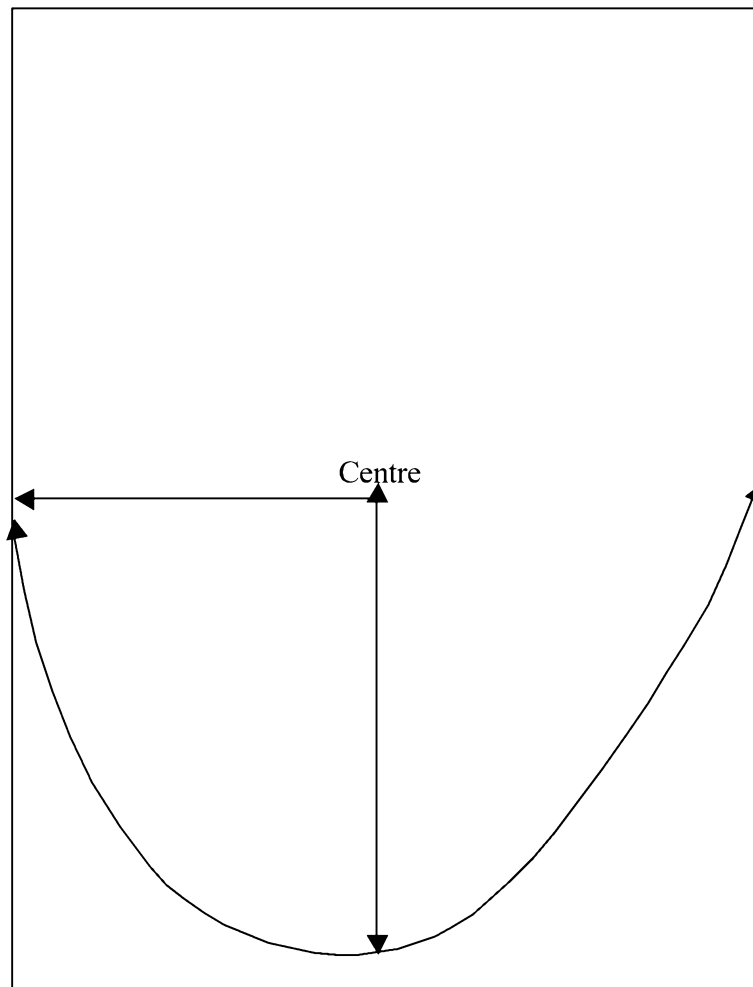

Fire Code Reform Project 2b

Early Fire Hazard Test

Test #:	RF1-1		
Date:	22/6/99		
Operator:	Russell Collins		
Material description:	Vinyl sheet		
Method of support:	No screen		
Substrate:	Cement sheet		
Thermocouple attachment:	Glue / incision		
Conditioning:	24 hours		
Video:	Yes ref:		
Time of first smoke:	HCl early in test		
Time of discolouration:			
Time of bulging:	Minor bulging		
Place of first ignition:	Top		
Smoke spill from hood:	Yes		
Test Duration (min):	6.7		
Time to ignition (min):	4.68	Ignitability Index:	15
Spread time (sec):	100	Spread of Flame Index:	5
Heat Integral (cm ²):	18.341	Heat Evolved Index:	4
Smoke Integral (cm ²):	16.792	Smoke Developed Index:	5

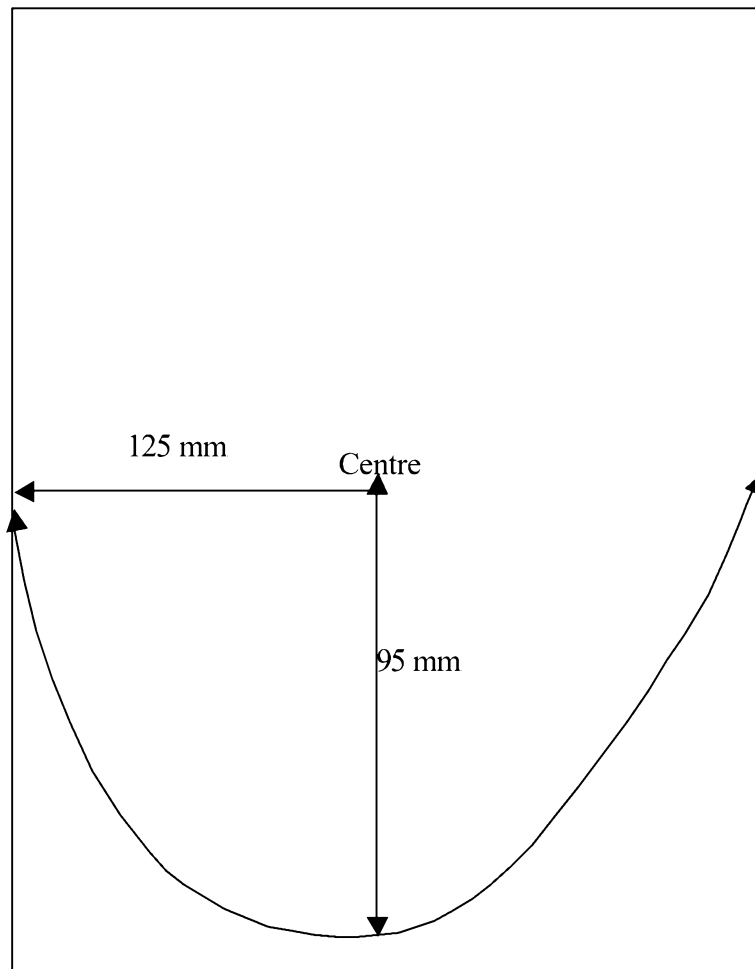

Fire Code Reform Project 2b

Early Fire Hazard Test

Test #:	RF1-2		
Date:	22/6/99		
Operator:	Russell Collins		
Material description:	Vinyl sheet		
Method of support:	Screen		
Substrate:	Cement sheet		
Thermocouple attachment:	Glue / incision		
Conditioning:	24 hours		
Video:	Yes ref:		
Time of first smoke:	HCl early in test		
Time of discolouration:			
Time of bulging:	Less bulging than without mesh		
Place of first ignition:	Top		
Smoke spill from hood:	Yes		
Test Duration (min):	7.7		
Time to ignition (min):	4.17	Ignitability Index:	16
Spread time (sec):	N/A	Spread of Flame Index:	0
Heat Integral (cm ²):	5.6507	Heat Evolved Index:	1
Smoke Integral (cm ²):	19.791	Smoke Developed Index:	6

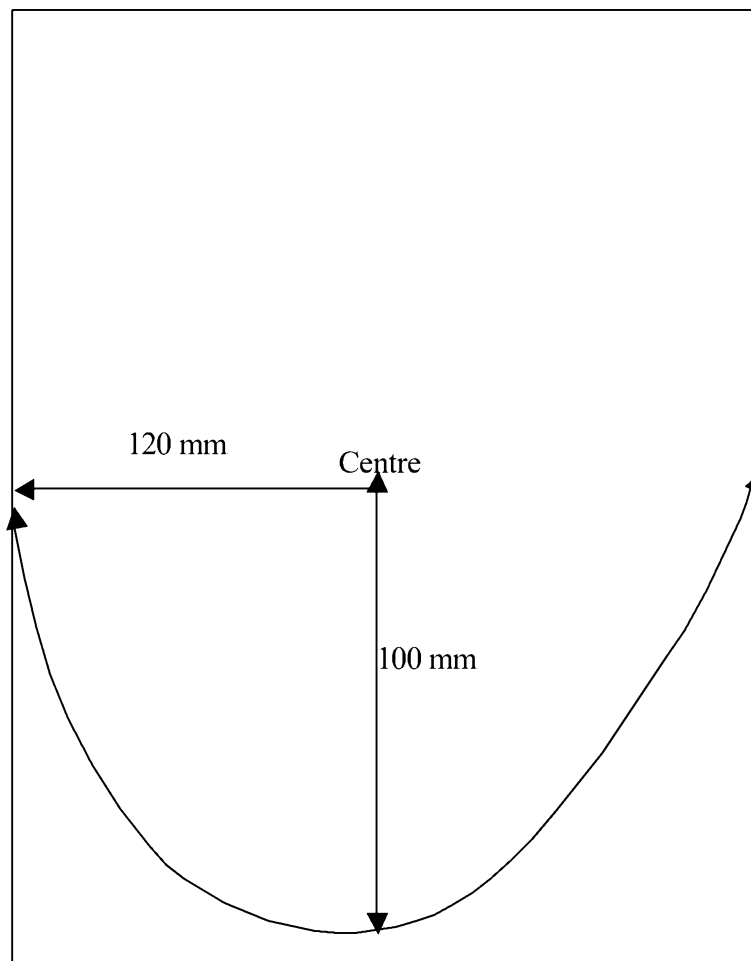

Fire Code Reform Project 2b

Early Fire Hazard Test

Test #:	P14-1		
Date:	22/6/99		
Operator:	Russell Collins		
Material description:	Polypropylene carpet		
Method of support:	Screen		
Substrate:	Calcium silicate board		
Thermocouple attachment:	Tucked in mesh		
Conditioning:	24 hours		
Video:	Yes ref:		
Time of first smoke:			
Time of discolouration:			
Time of bulging:	Melting at 2.2 min		
Place of first ignition:	Centre		
Smoke spill from hood:	No		
Test Duration (min):	6.1		
Time to ignition (min):	4.02	Ignitability Index:	16
Spread time (sec):	30	Spread of Flame Index:	8
Heat Integral (cm ²):	37.116	Heat Evolved Index:	8
Smoke Integral (cm ²):	14.817	Smoke Developed Index:	5

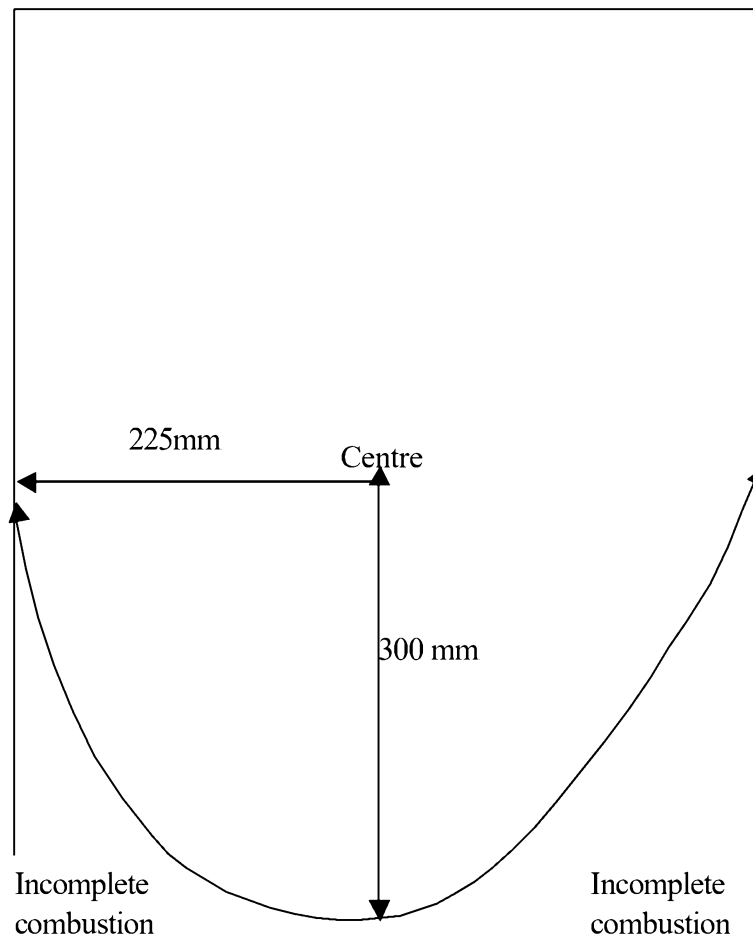

Fire Code Reform Project 2b

Early Fire Hazard Test

Test #:	P14-2		
Date:	22/6/99		
Operator:	Russell Collins		
Material description:	Polypropylene carpet		
Method of support:	Screen		
Substrate:	Calcium silicate board		
Thermocouple attachment:	Tucked in mesh		
Conditioning:	24 hours		
Video:	Yes ref:		
Time of first smoke:	2.2 min		
Time of discolouration:			
Time of bulging:	Melting at 2.2 min; pulled away from mesh 2.6 min		
Place of first ignition:	Centre		
Smoke spill from hood:			
Test Duration (min):	6.0		
Time to ignition (min):	3.88	Ignitability Index:	16
Spread time (sec):	33	Spread of Flame Index:	8
Heat Integral (cm ²):	43.808	Heat Evolved Index:	10
Smoke Integral (cm ²):	22.999	Smoke Developed Index:	6

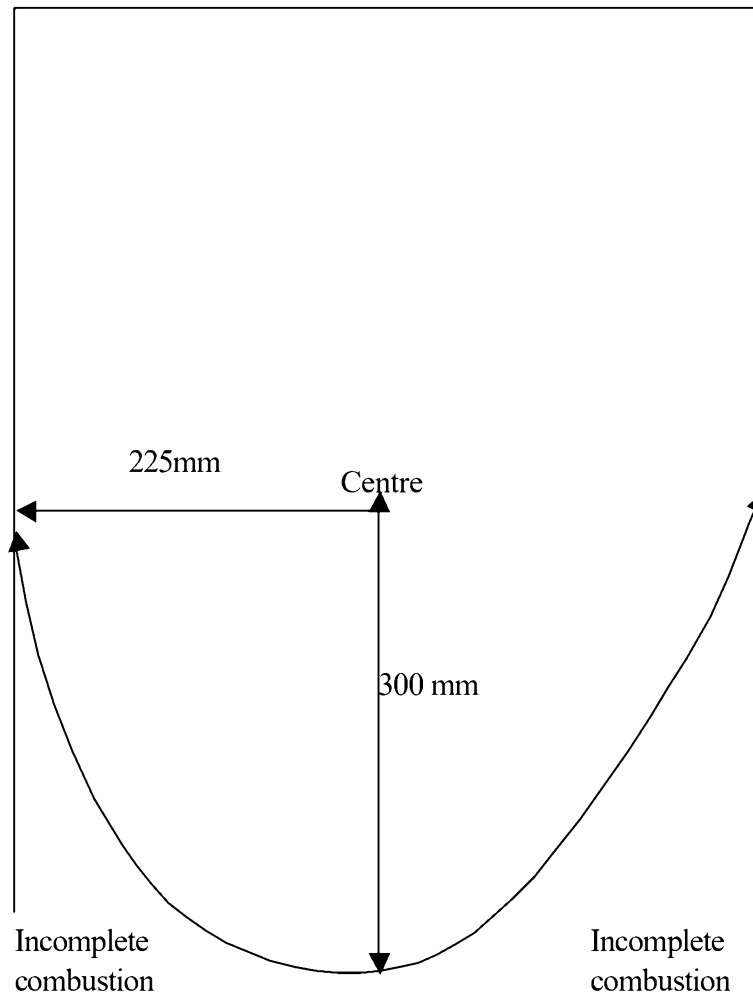

Fire Code Reform Project 2b

Early Fire Hazard Test

Test #:	N20-1		
Date:	22/6/99		
Operator:	Russell Collins		
Material description:	Nylon carpet		
Method of support:	Screen		
Substrate:	Cement sheet		
Thermocouple attachment:	Tucked in mesh		
Conditioning:	24 hours		
Video:	Yes ref:		
Time of first smoke:	1.7 min (HCl)		
Time of discolouration:			
Time of bulging:			
Place of first ignition:	Centre		
Smoke spill from hood:	Yes – soon after ignition		
Test Duration (min):	6.2		
Time to ignition (min):	4.13	Ignitability Index:	16
Spread time (sec):	19	Spread of Flame Index:	9
Heat Integral (cm ²):	30.788	Heat Evolved Index:	7
Smoke Integral (cm ²):	31.444	Smoke Developed Index:	7

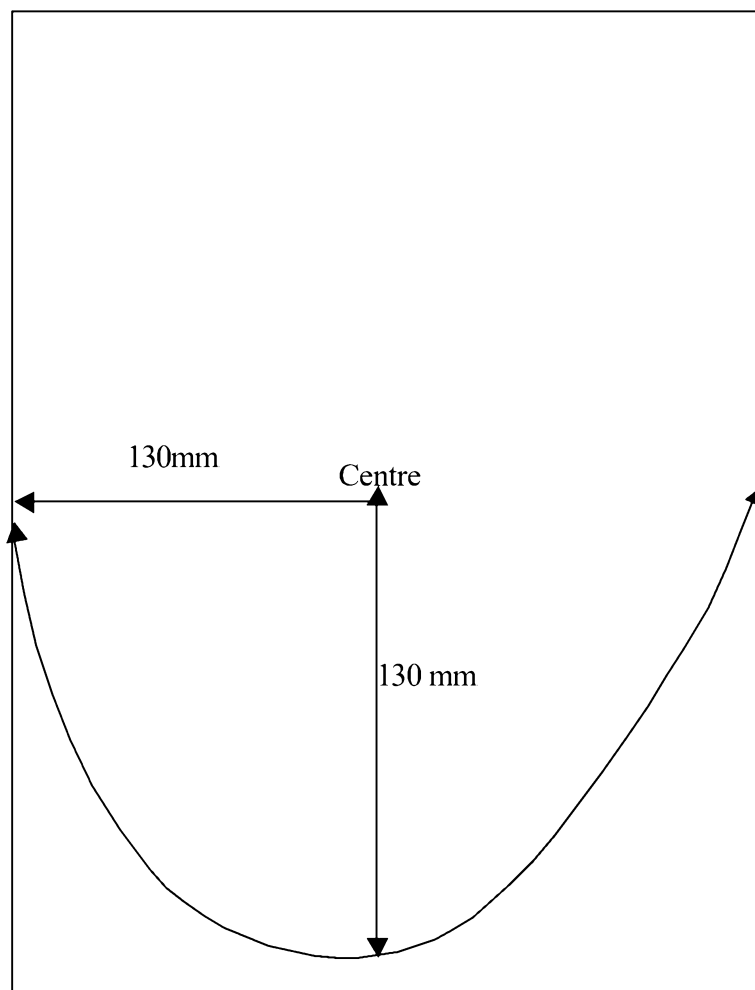

Fire Code Reform Project 2b

Early Fire Hazard Test

Test #:	N20-2		
Date:	22/6/99		
Operator:	Russell Collins		
Material description:	Nylon carpet		
Method of support:	Screen		
Substrate:	Cement sheet		
Thermocouple attachment:	Tucked in mesh		
Conditioning:	24 hours		
Video:	Yes ref:		
Time of first smoke:	2.1 min		
Time of discolouration:			
Time of bulging:			
Place of first ignition:	Centre		
Smoke spill from hood:	Yes – before ignition		
Test Duration (min):	6.4		
Time to ignition (min):	4.30	Ignitability Index:	16
Spread time (sec):	24	Spread of Flame Index:	8
Heat Integral (cm ²):	29.622	Heat Evolved Index:	7
Smoke Integral (cm ²):	36.285	Smoke Developed Index:	7

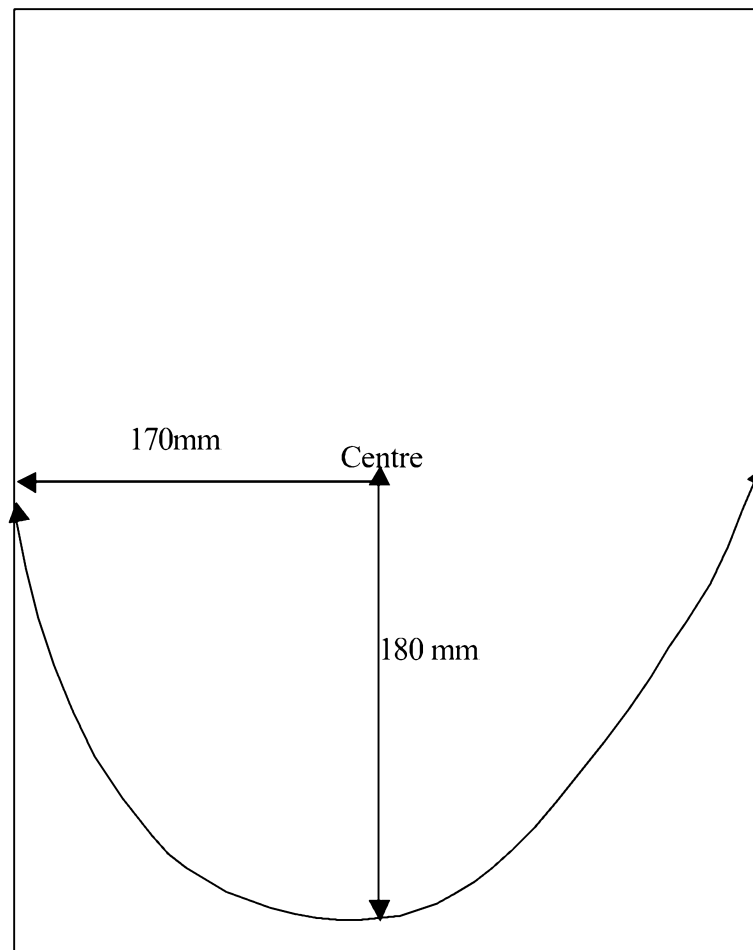

Fire Code Reform Project 2b

Early Fire Hazard Test

Test #:	N20-3		
Date:	22/6/99		
Operator:	Russell Collins		
Material description:	Nylon carpet		
Method of support:	Screen		
Substrate:	Calcium silicate board		
Thermocouple attachment:	Tucked in mesh		
Conditioning:	24 hours		
Video:	Yes ref:		
Time of first smoke:	1.8 min		
Time of discolouration:			
Time of bulging:			
Place of first ignition:	Centre		
Smoke spill from hood:	Yes		
Test Duration (min):	5.8		
Time to ignition (min):	3.77	Ignitability Index:	16
Spread time (sec):	12	Spread of Flame Index:	9
Heat Integral (cm ²):	35.984	Heat Evolved Index:	8
Smoke Integral (cm ²):	34.918	Smoke Developed Index:	7

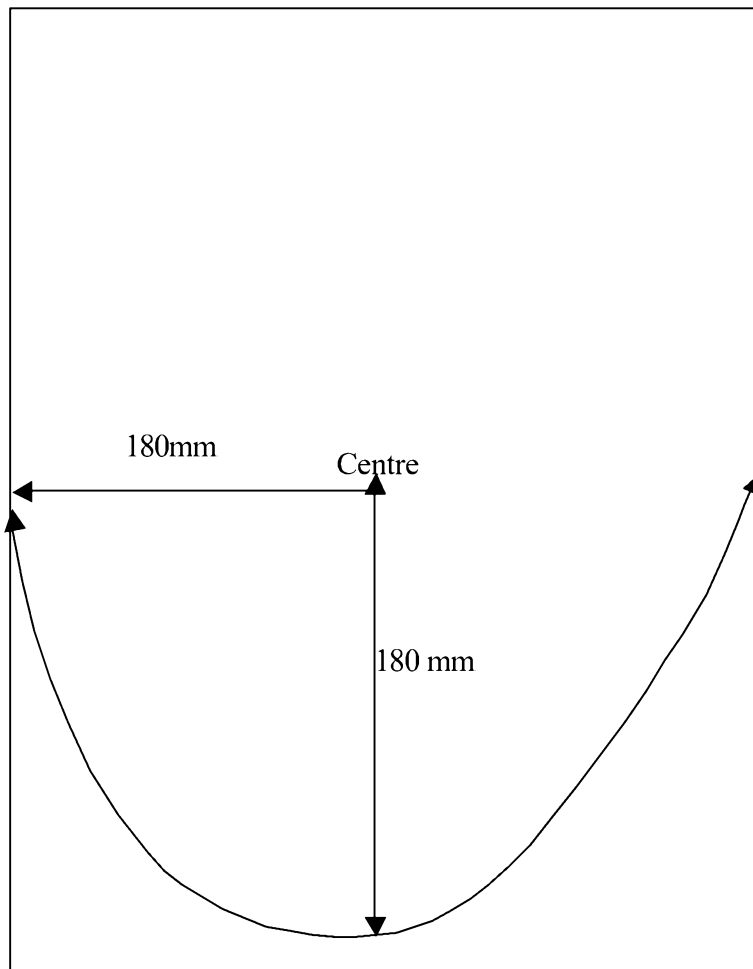

Fire Code Reform Project 2b

Early Fire Hazard Test

Test #:	N20-4		
Date:	22/6/99		
Operator:	Russell Collins		
Material description:	Polypropylene carpet		
Method of support:	Screen		
Substrate:	Calcium silicate board		
Thermocouple attachment:	Tucked in mesh and deeply embedded in pile		
Conditioning:	24 hours		
Video:	Yes ref:		
Time of first smoke:	1.8 min		
Time of discolouration:			
Time of bulging:			
Place of first ignition:	Centre		
Smoke spill from hood:	Yes		
Test Duration (min):	5.6		
Time to ignition (min):	3.47	Ignitability Index:	17
Spread time (sec):	20	Spread of Flame Index:	9
Heat Integral (cm ²):	36.133	Heat Evolved Index:	8
Smoke Integral (cm ²):	37.322	Smoke Developed Index:	7

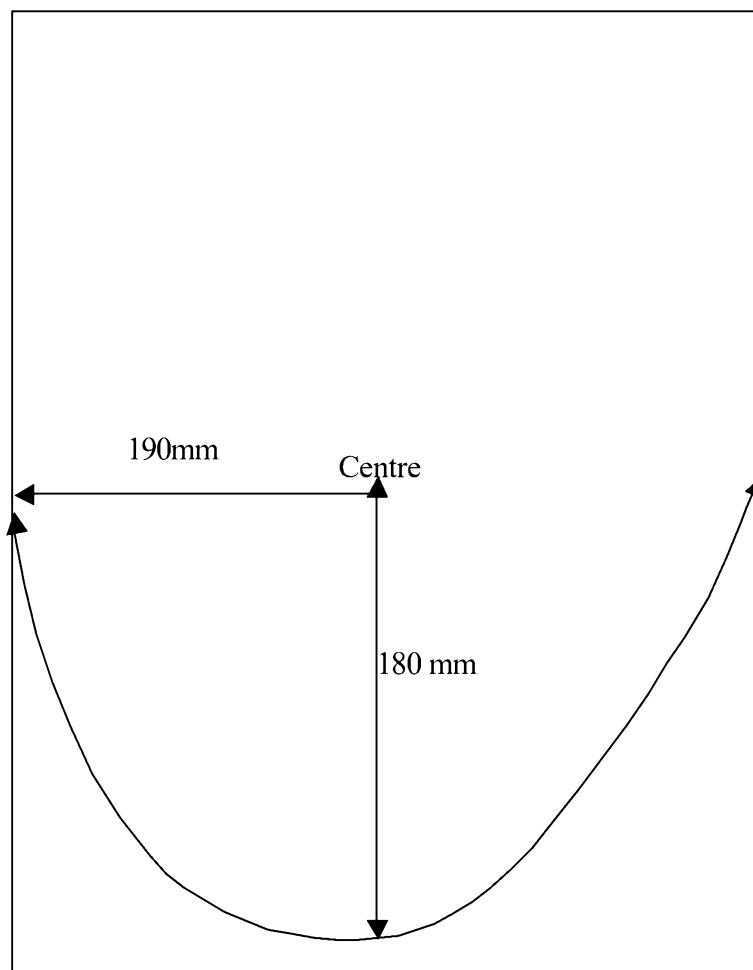

FCRC Project 2: EFH Results

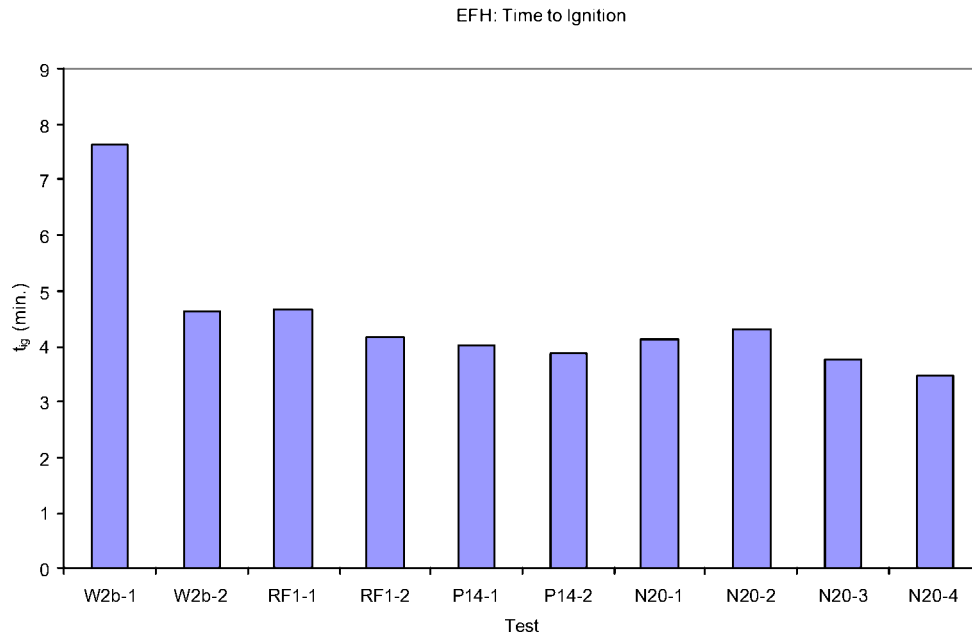

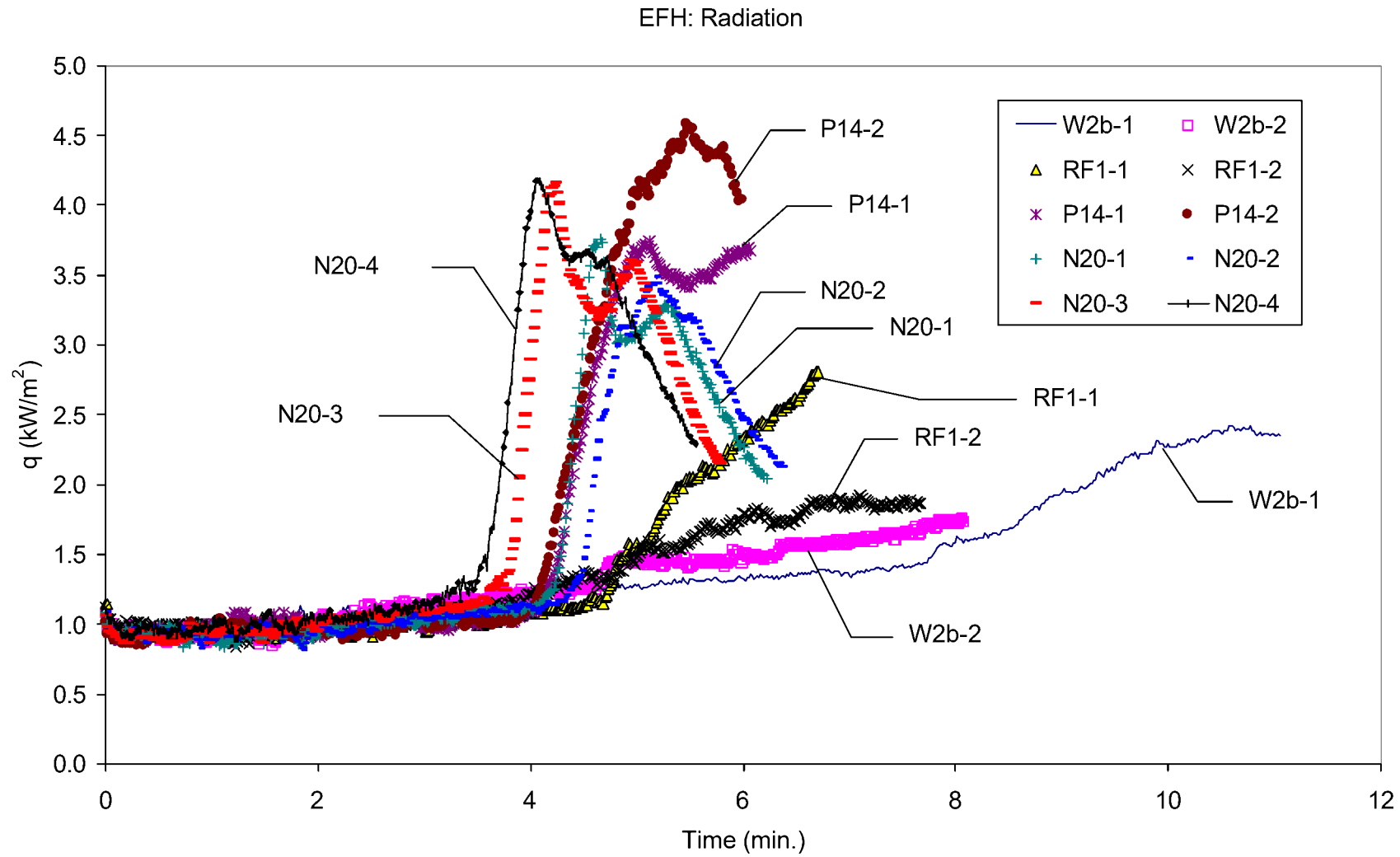

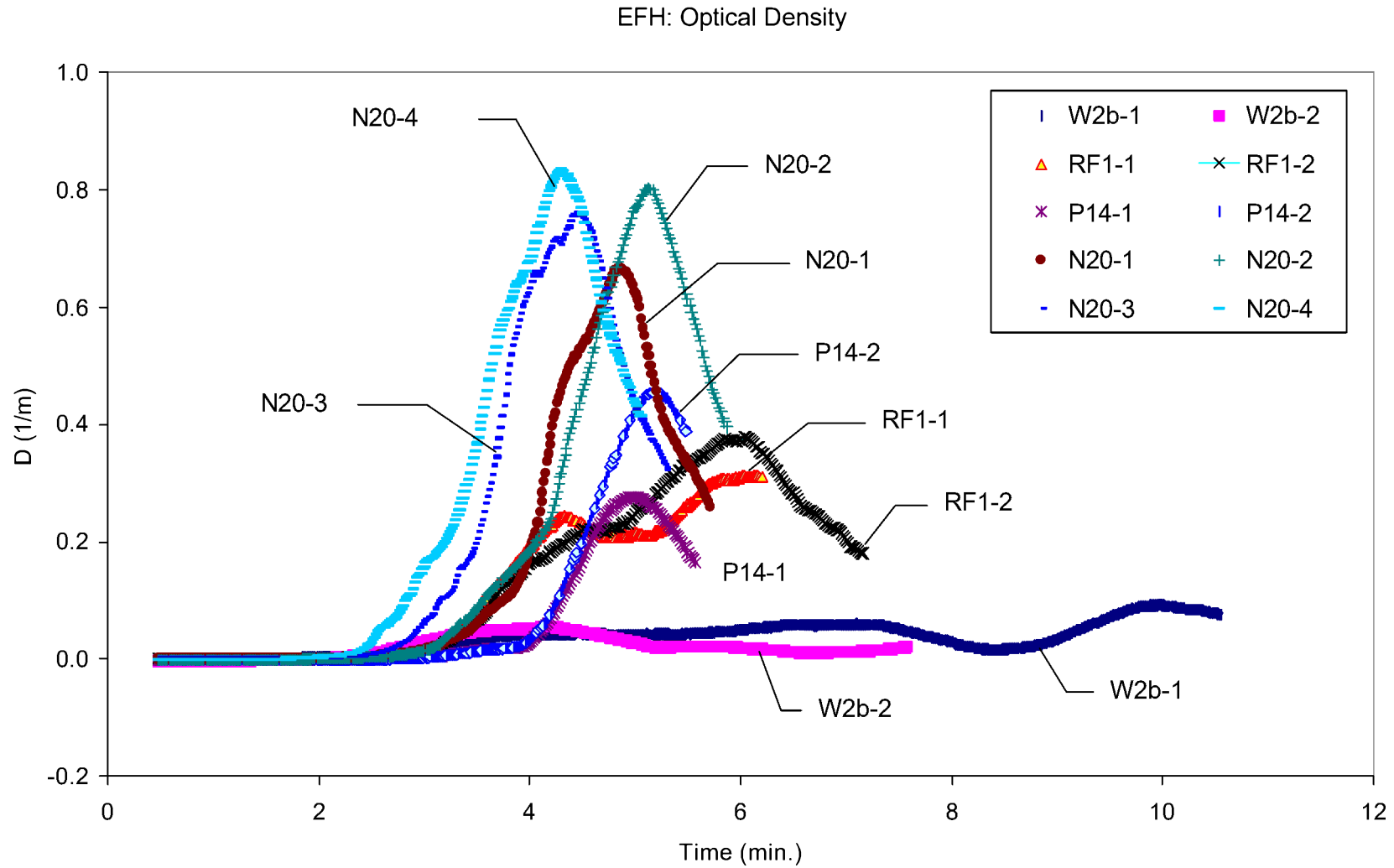

W2b-1

Test E7507-S1

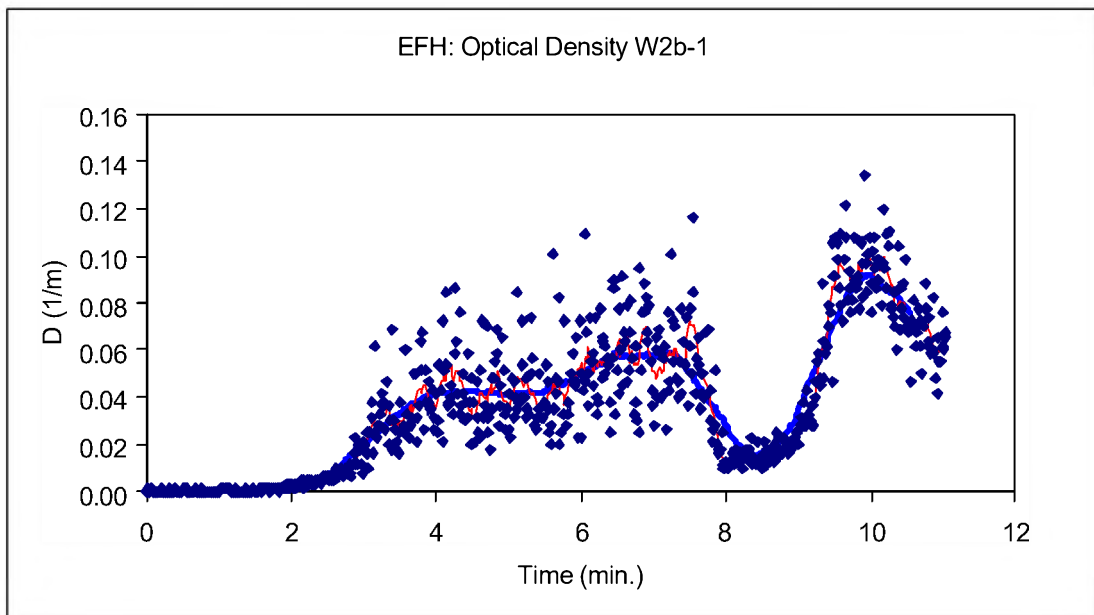
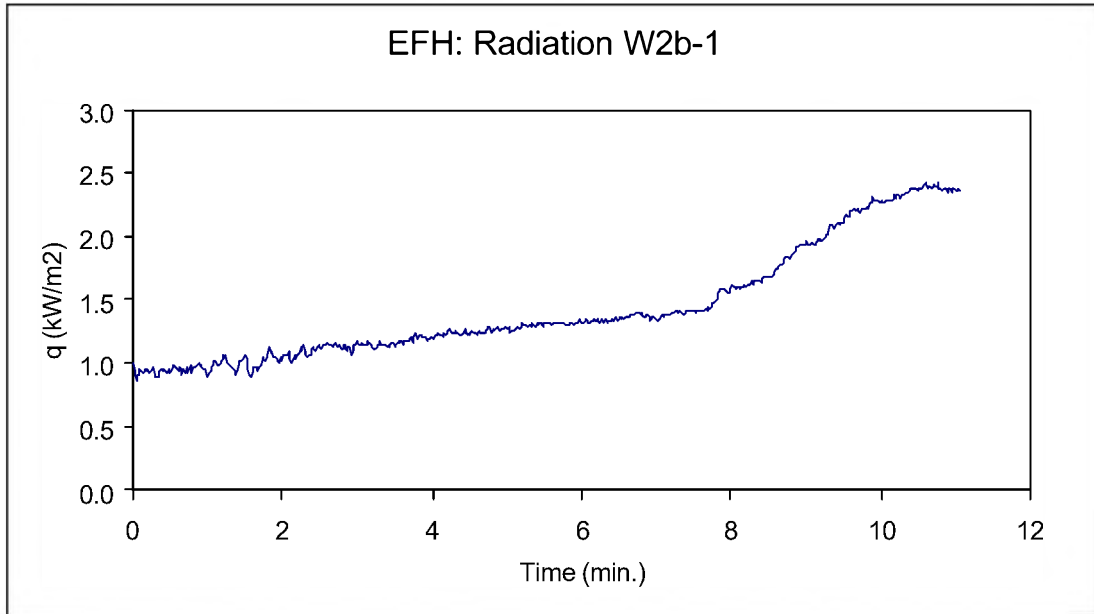

W2b-2

Test E7507-S2

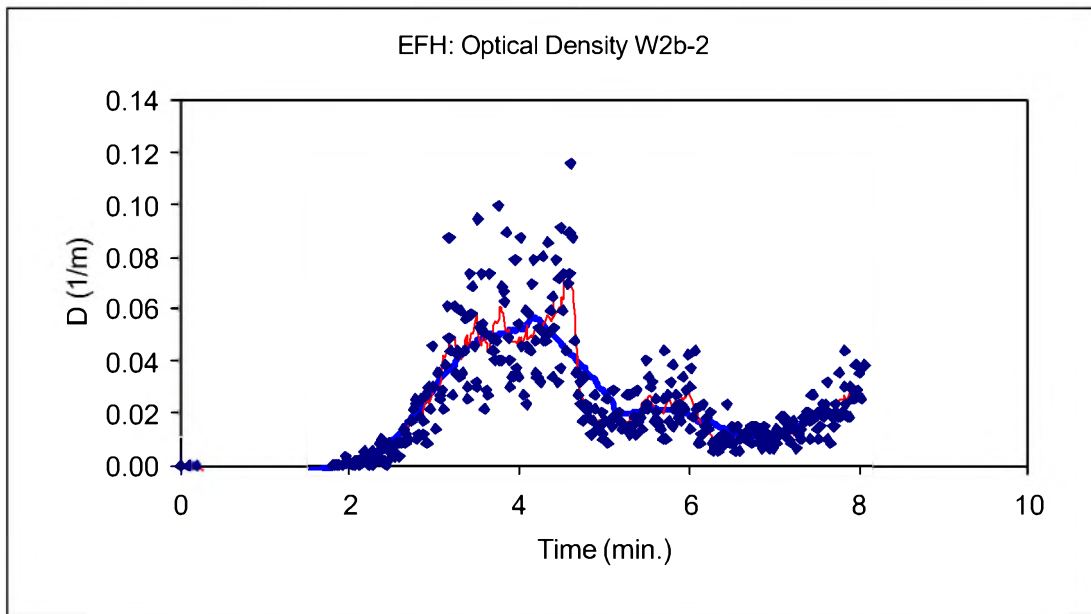
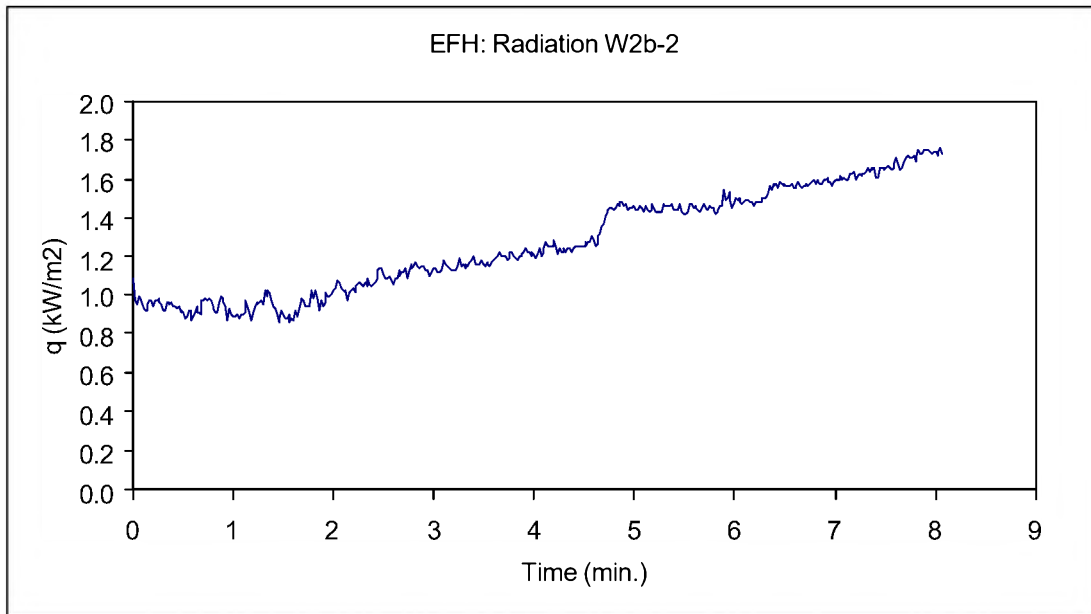

RF1-1

Test E7508-S1

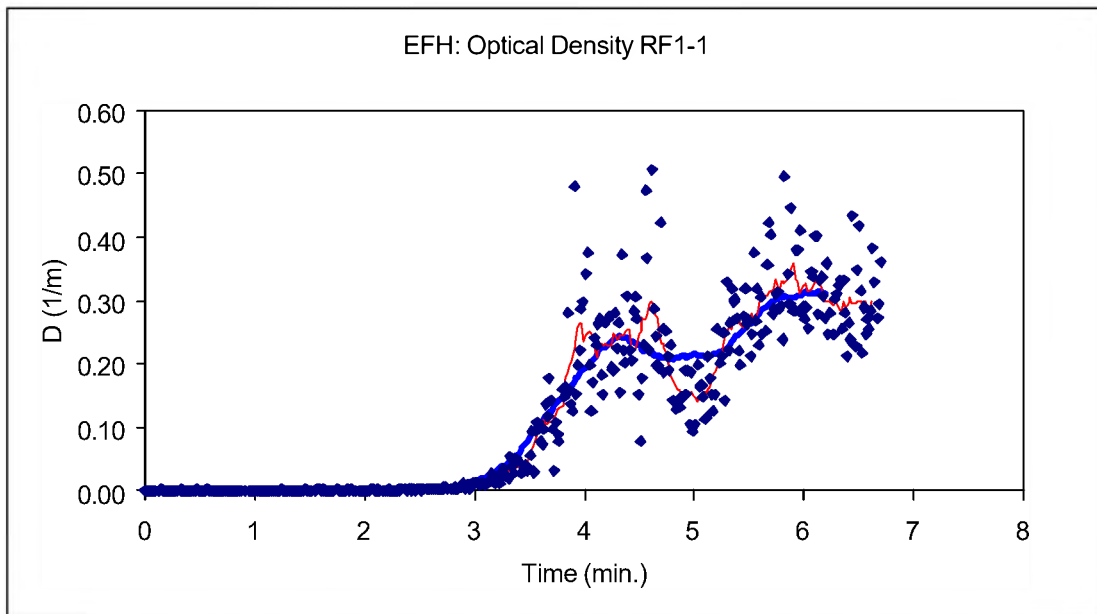
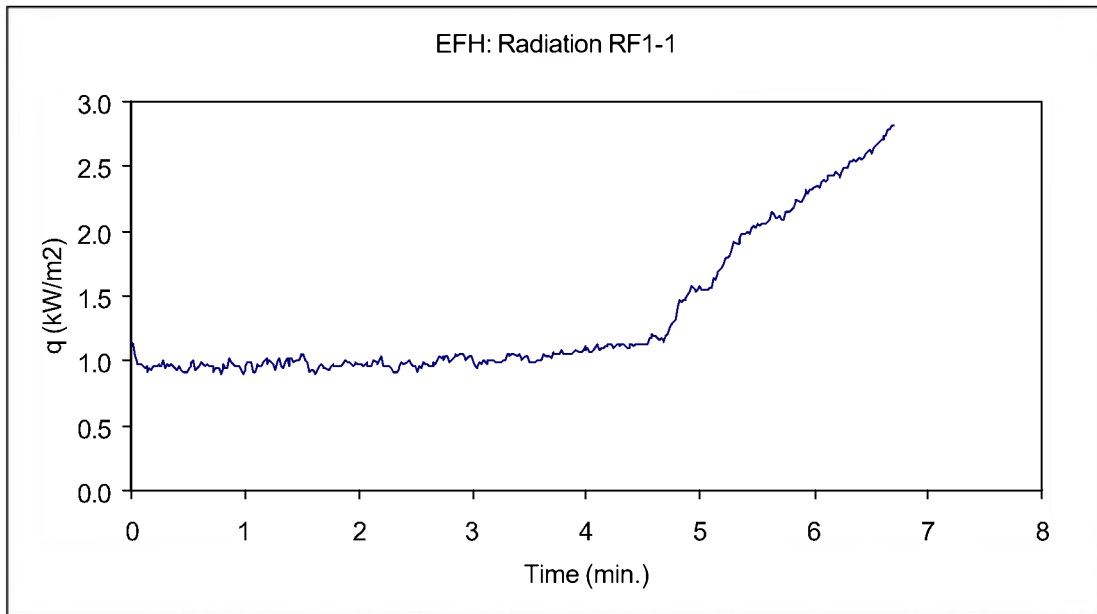

RF1-2

Test E7508-S2

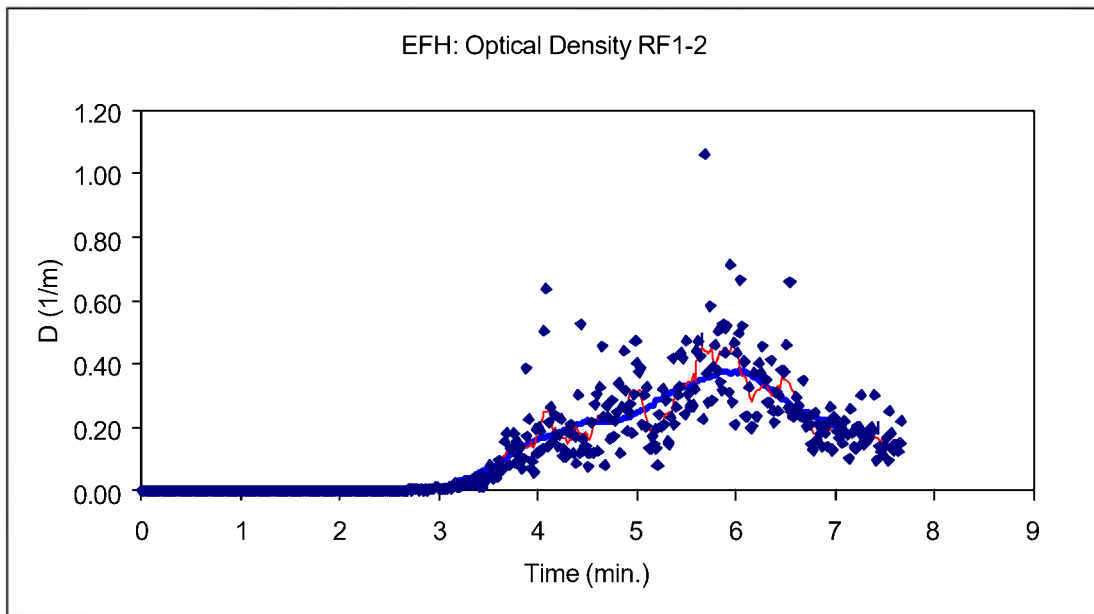
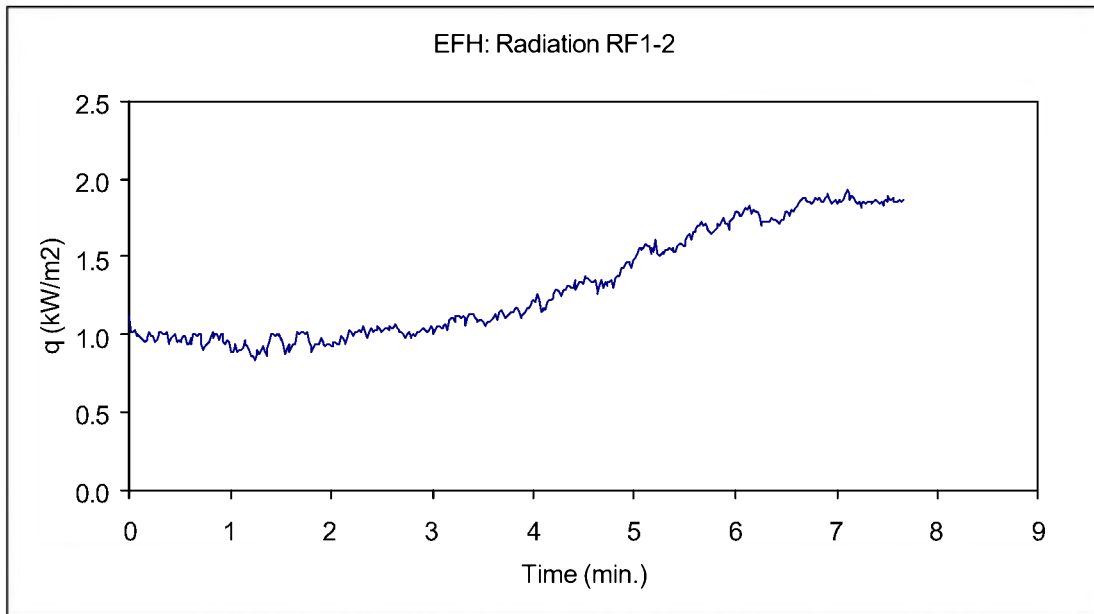

P14-1

Test E7509-S1

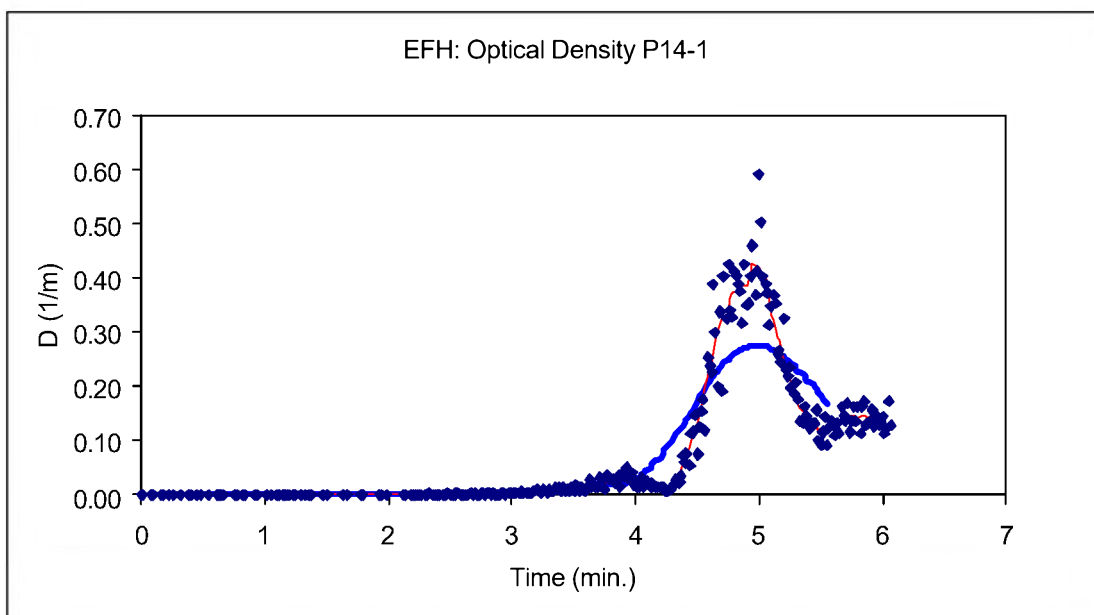
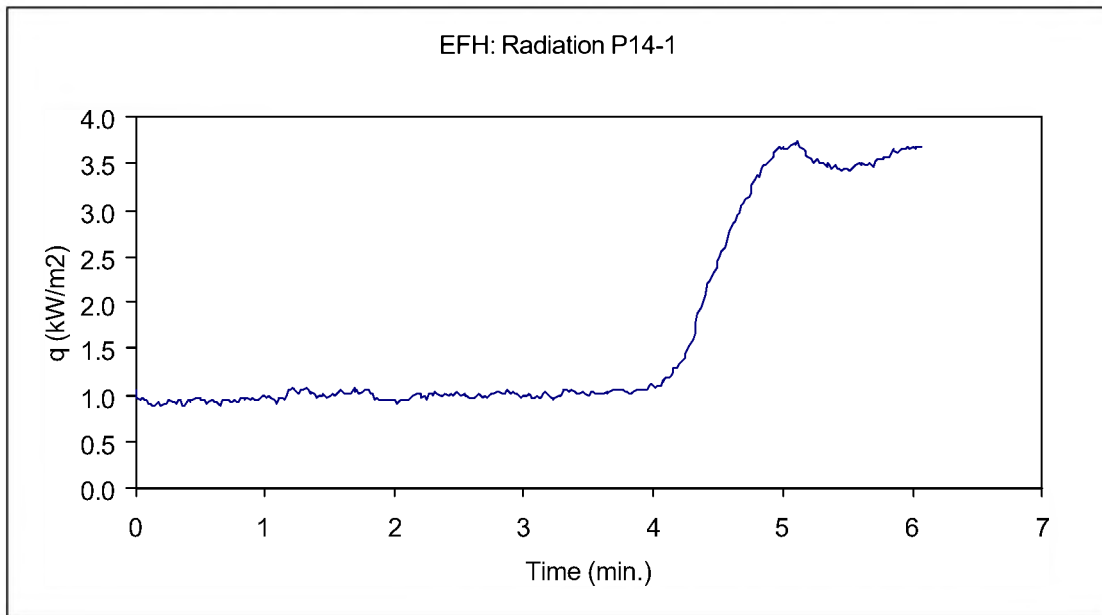

P14-2

E7509-S2

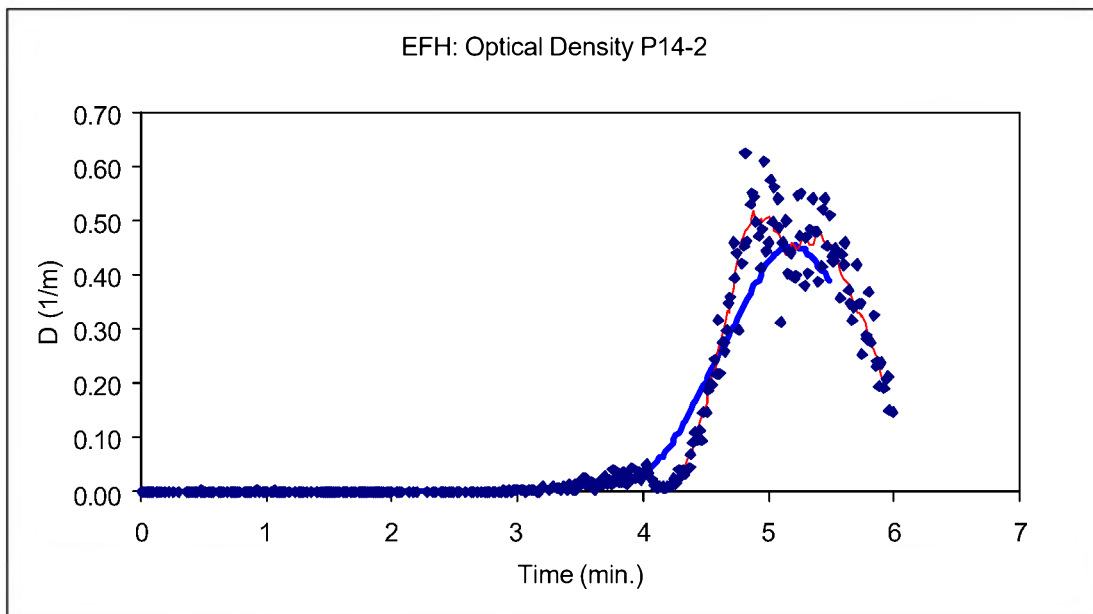
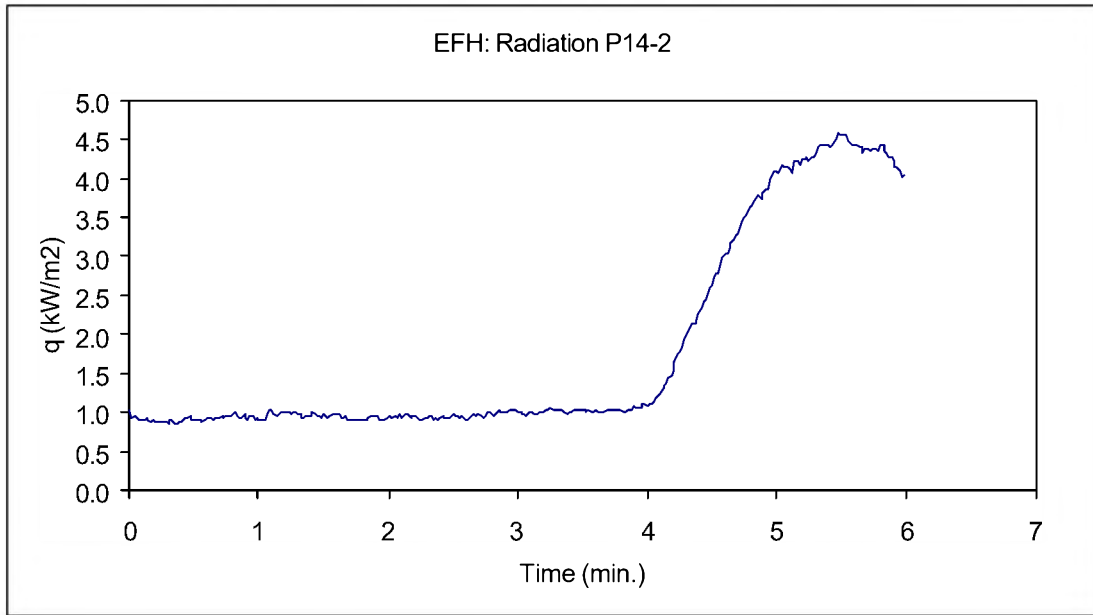

N20-1

Test E7510-S1

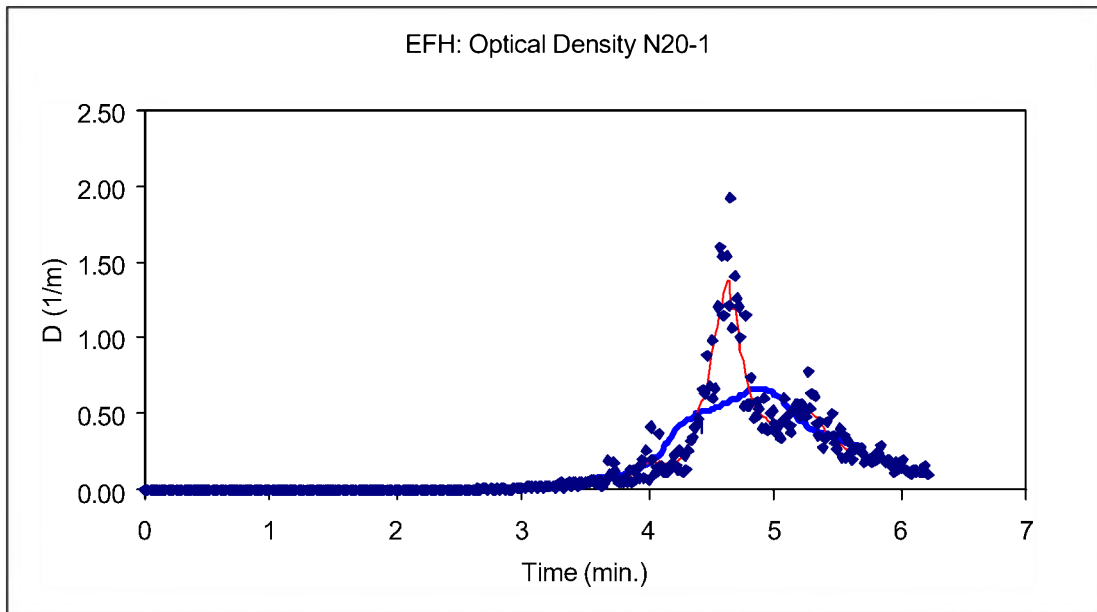
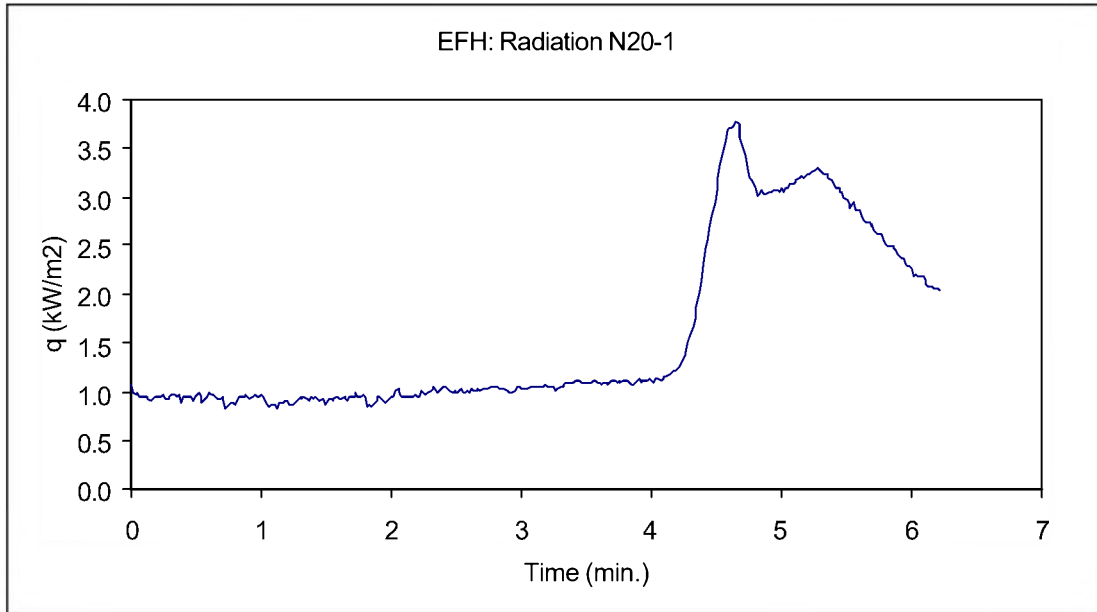

N20-2

Test E7510-S2

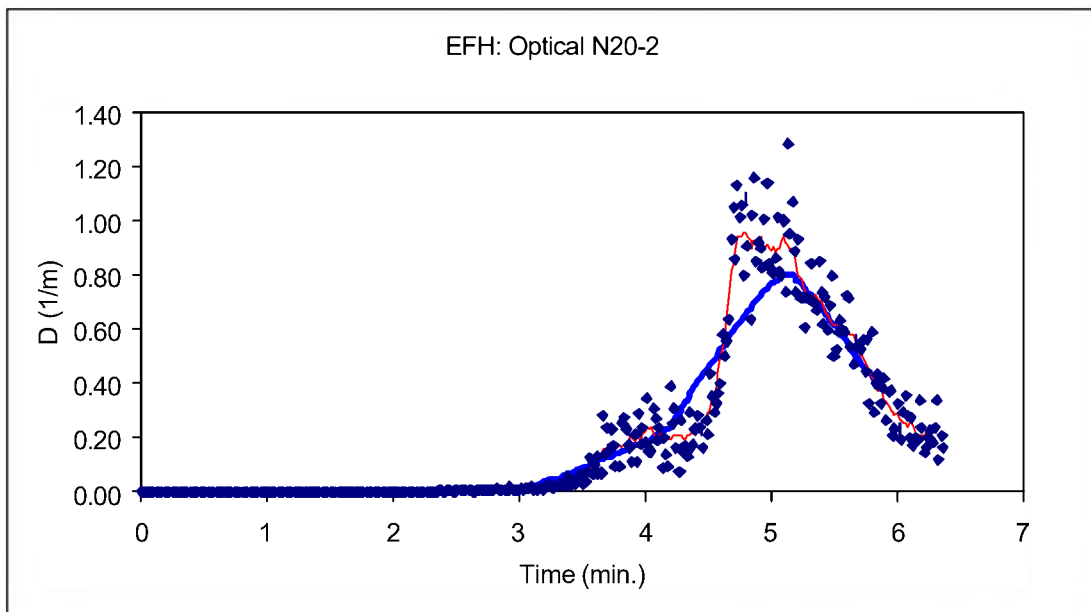
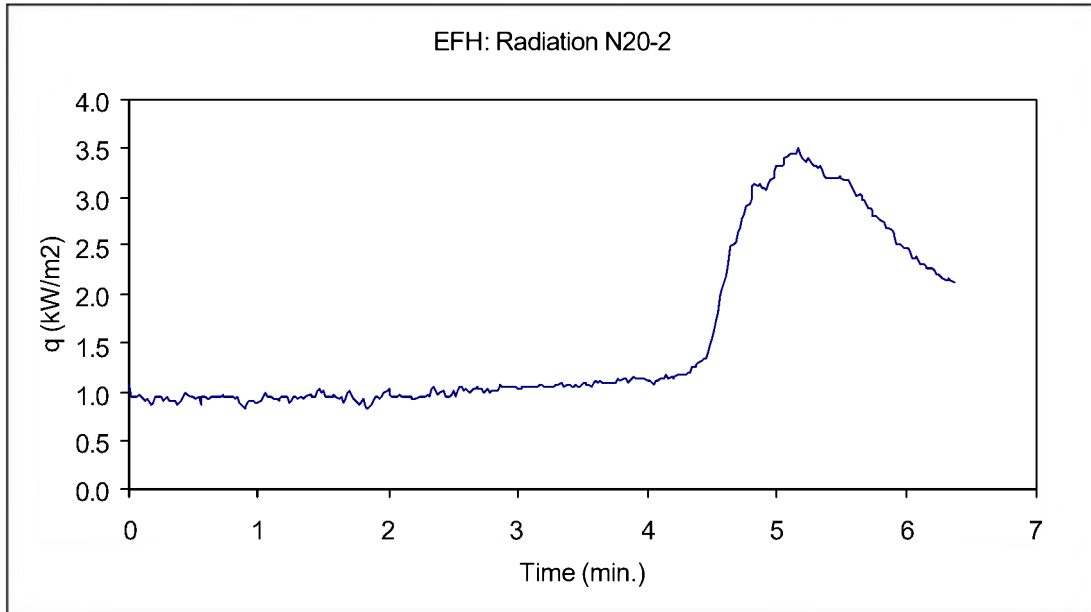

N20-3

E7511-S1

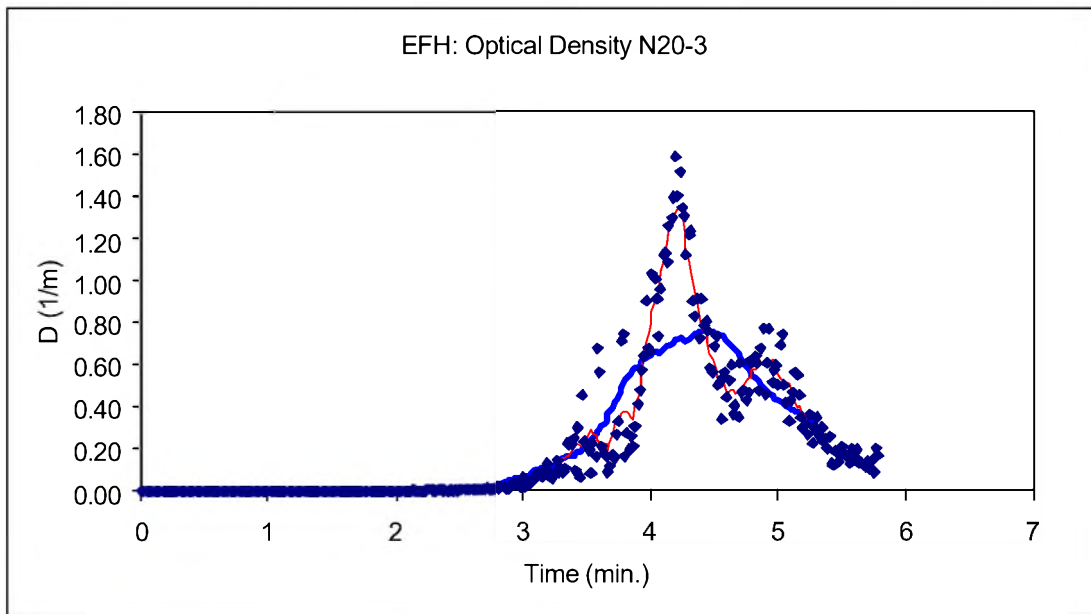
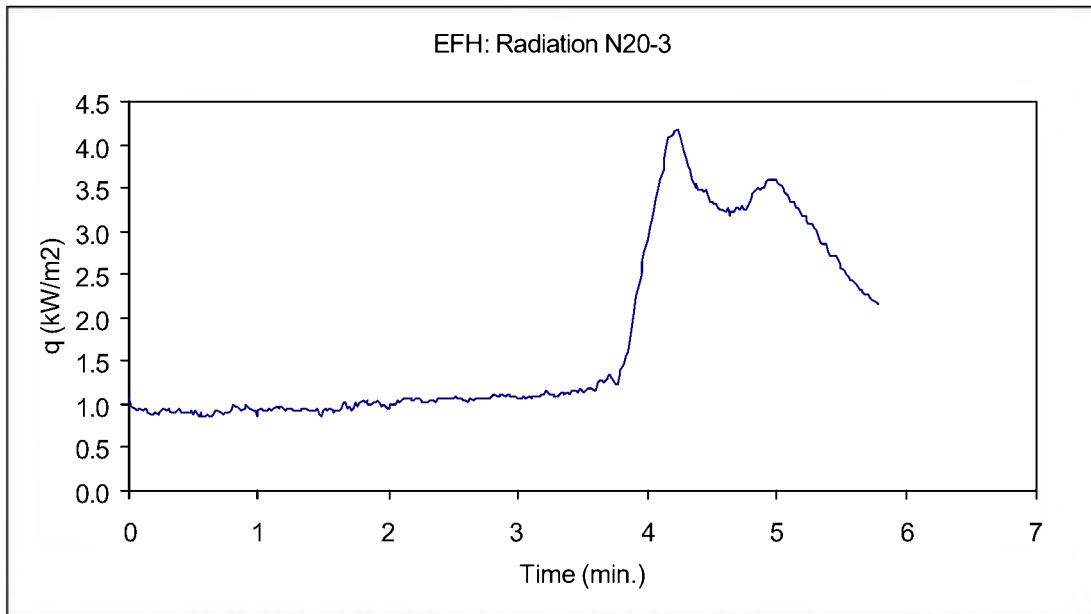

N20-4

Test E7511-S2

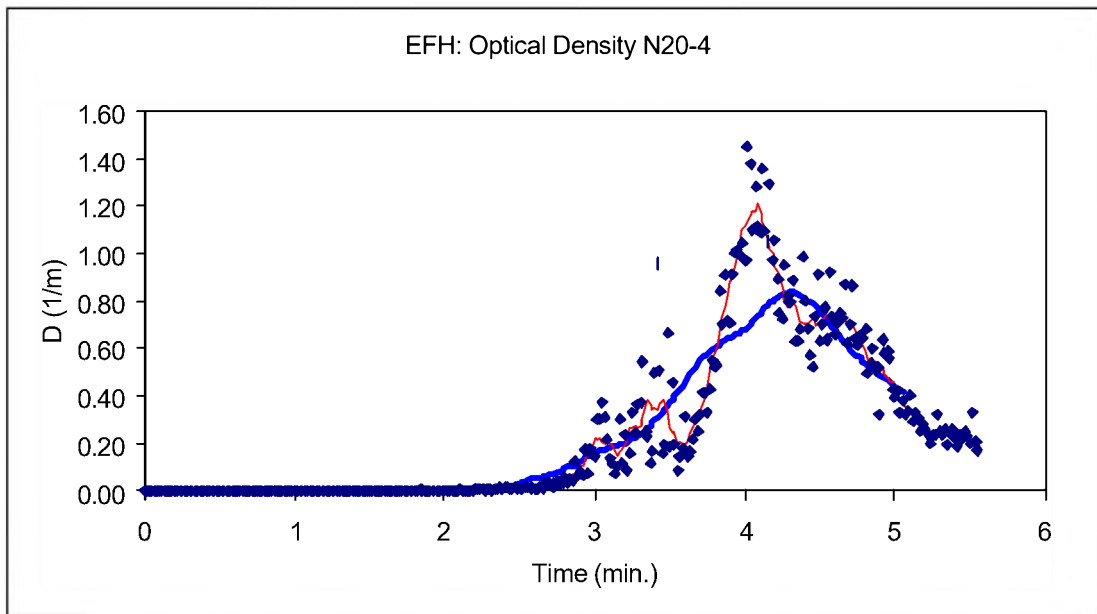
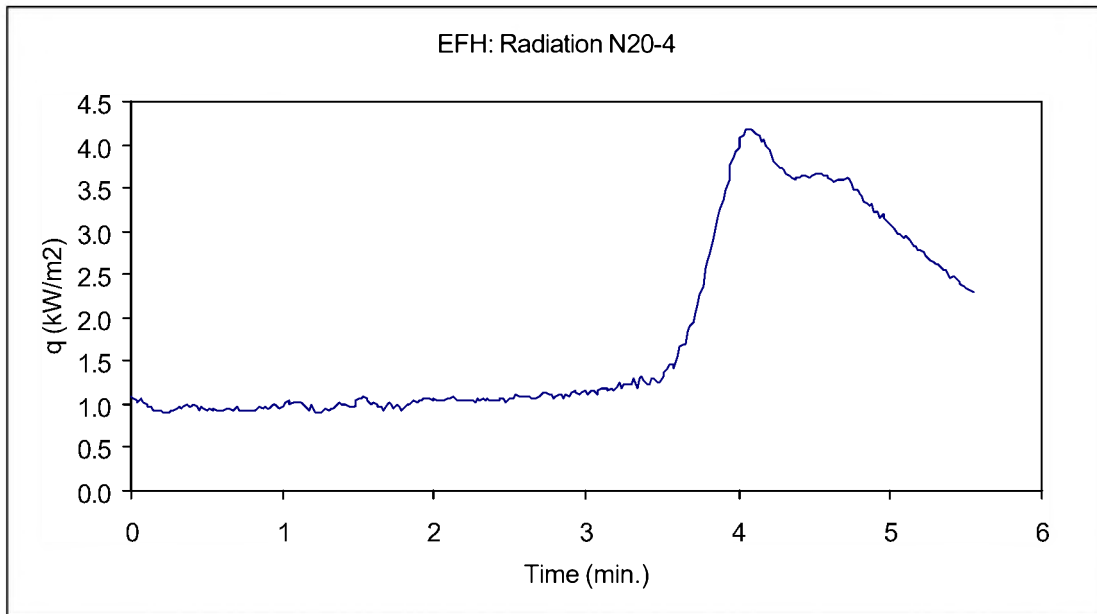

EFH: Temperature

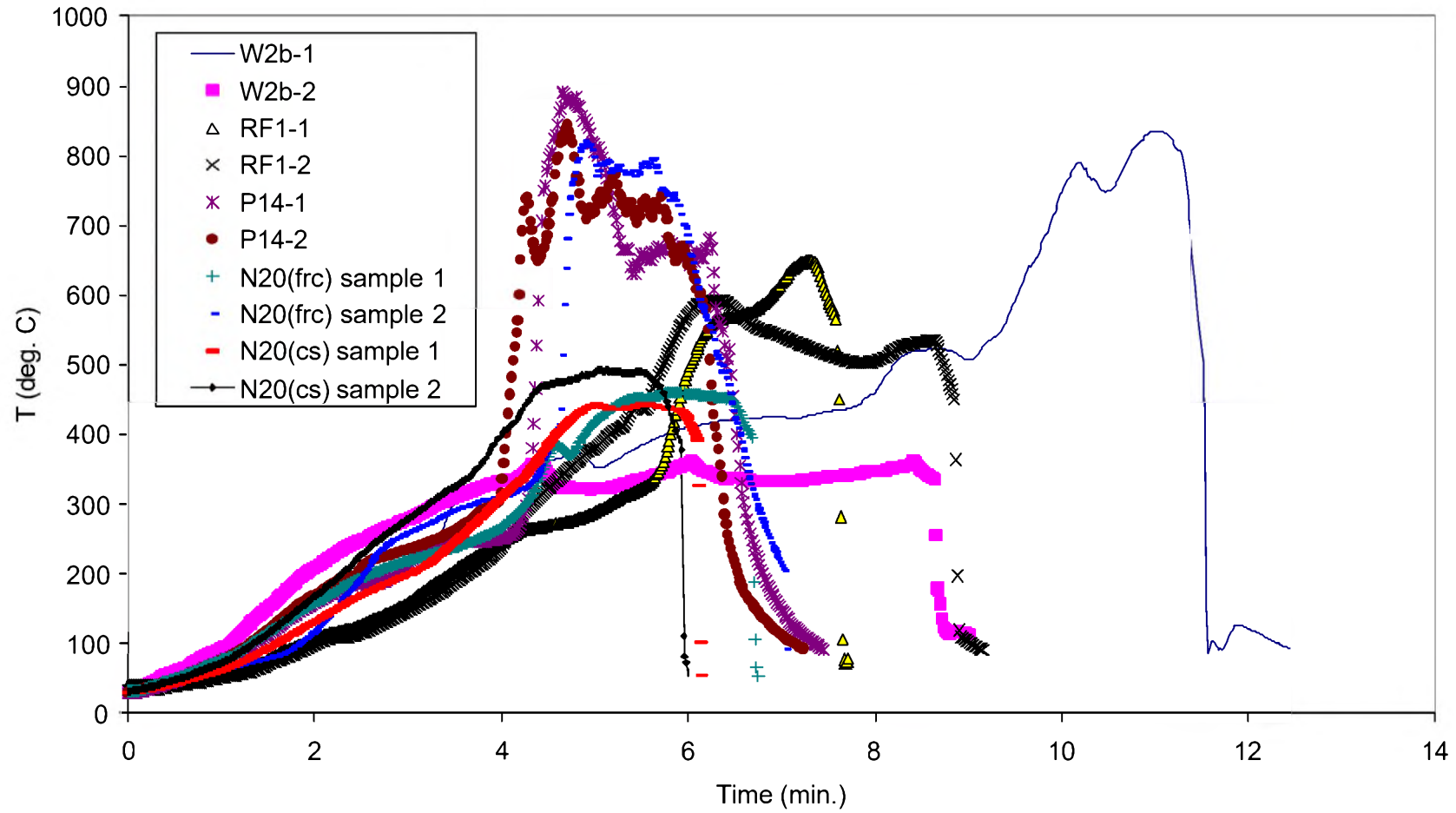

W2b-1

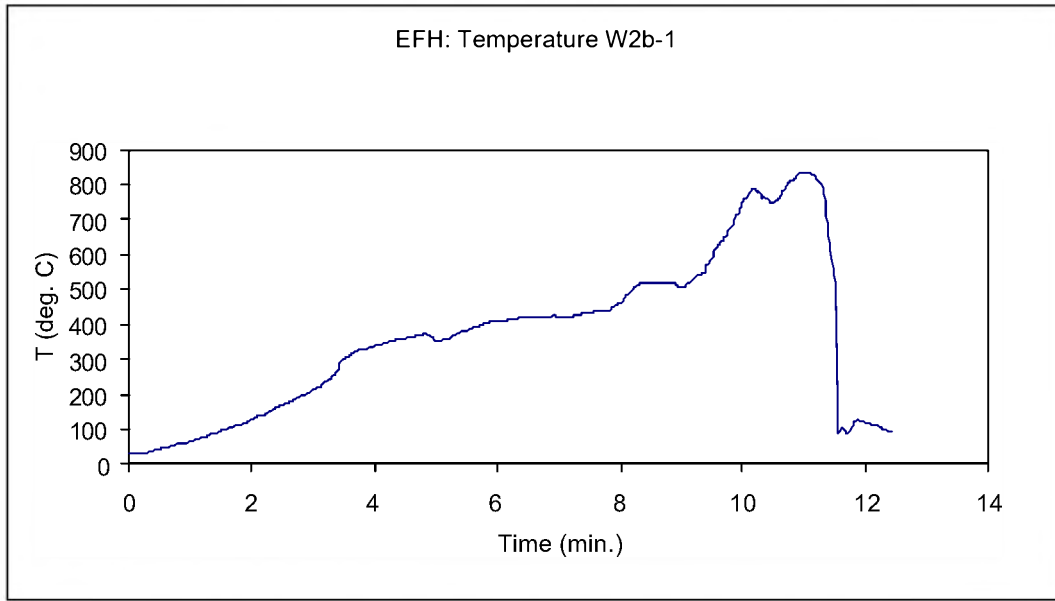

W2b-2

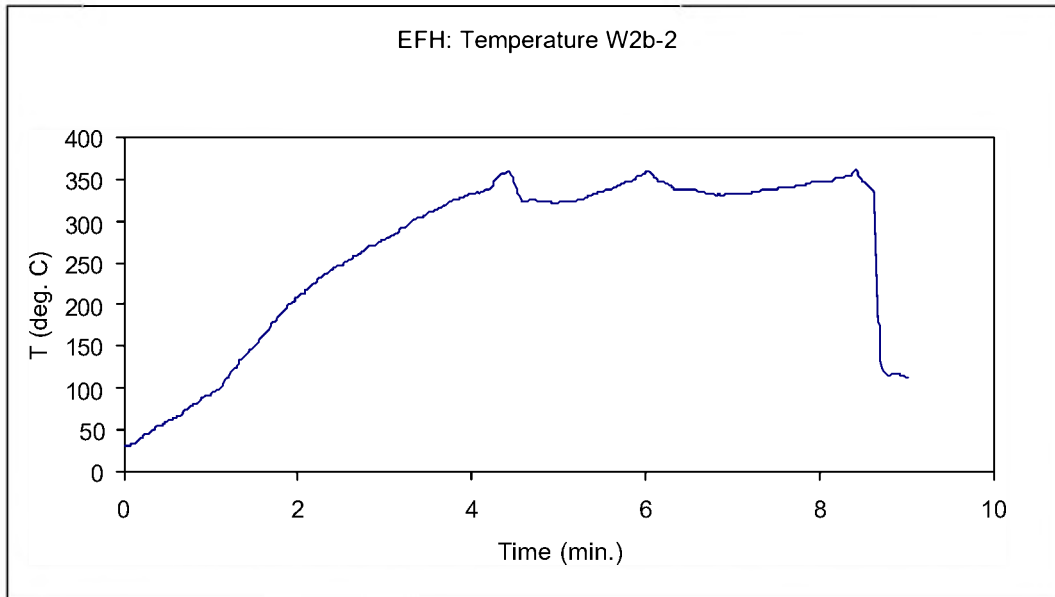

RF1-1

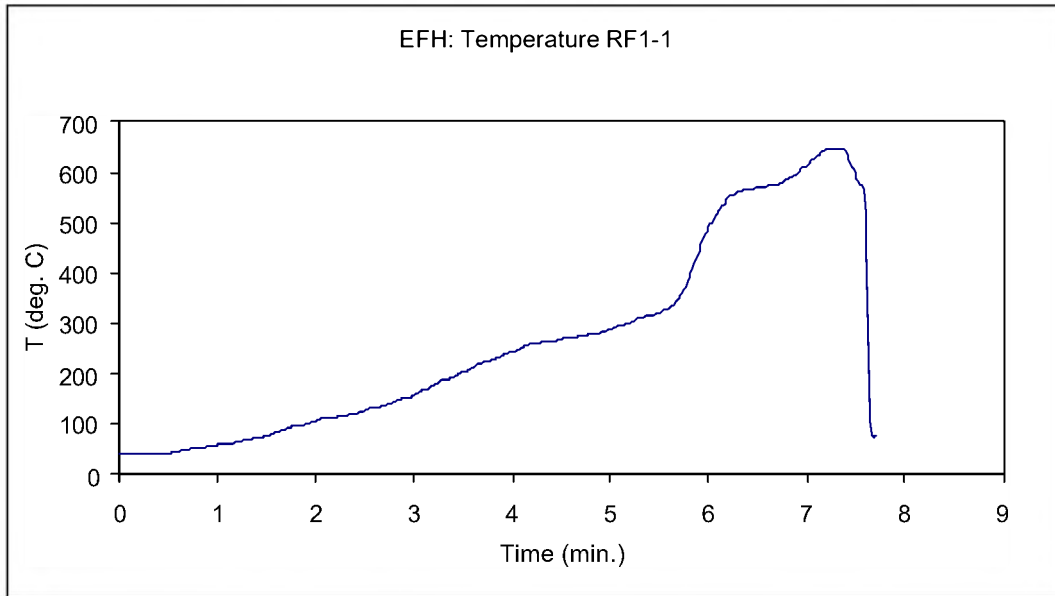

RF1-2

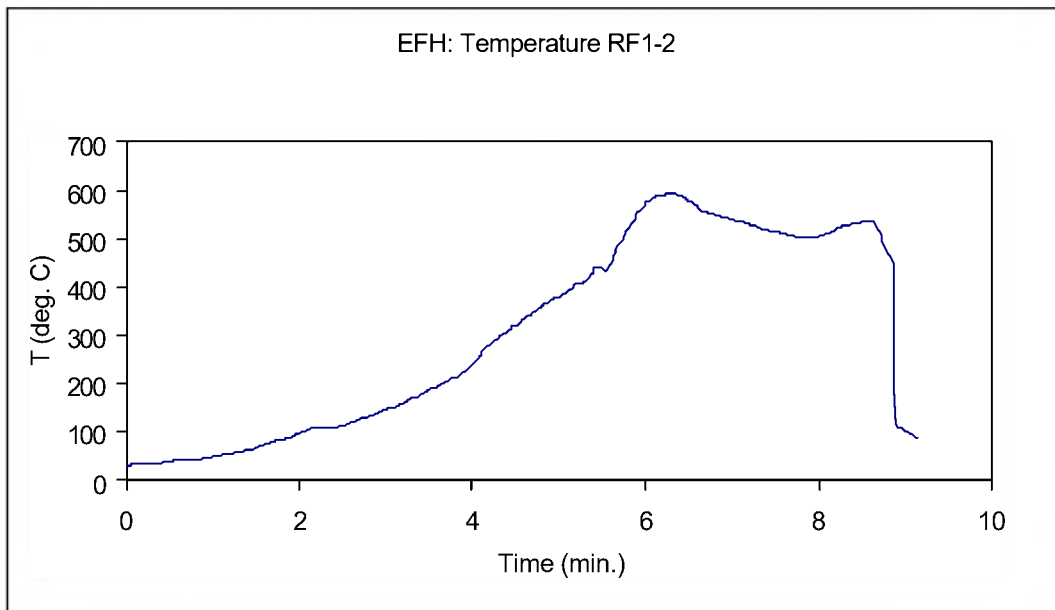

P14-1

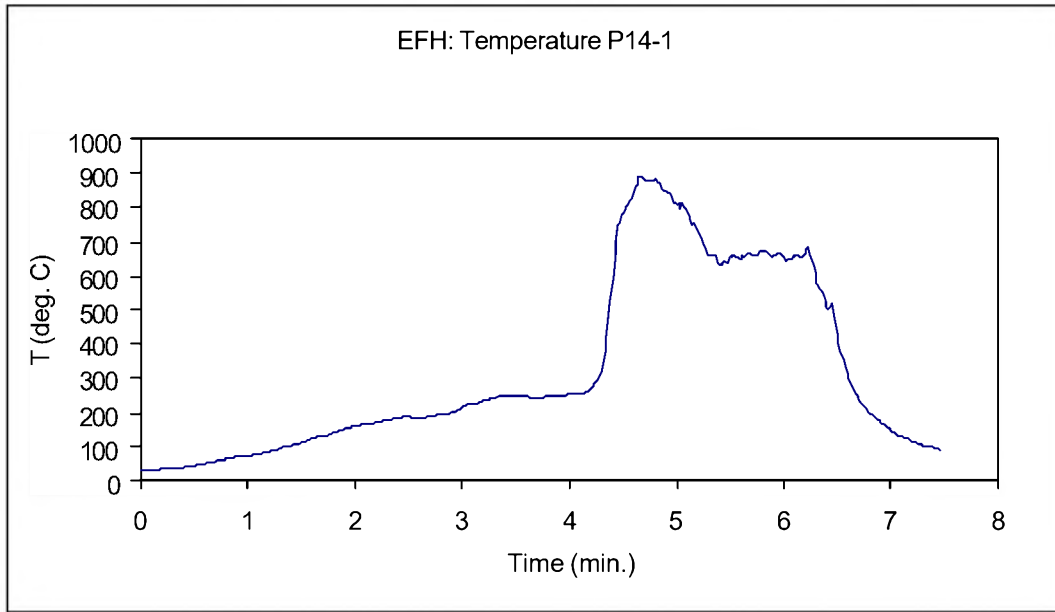

P14-2

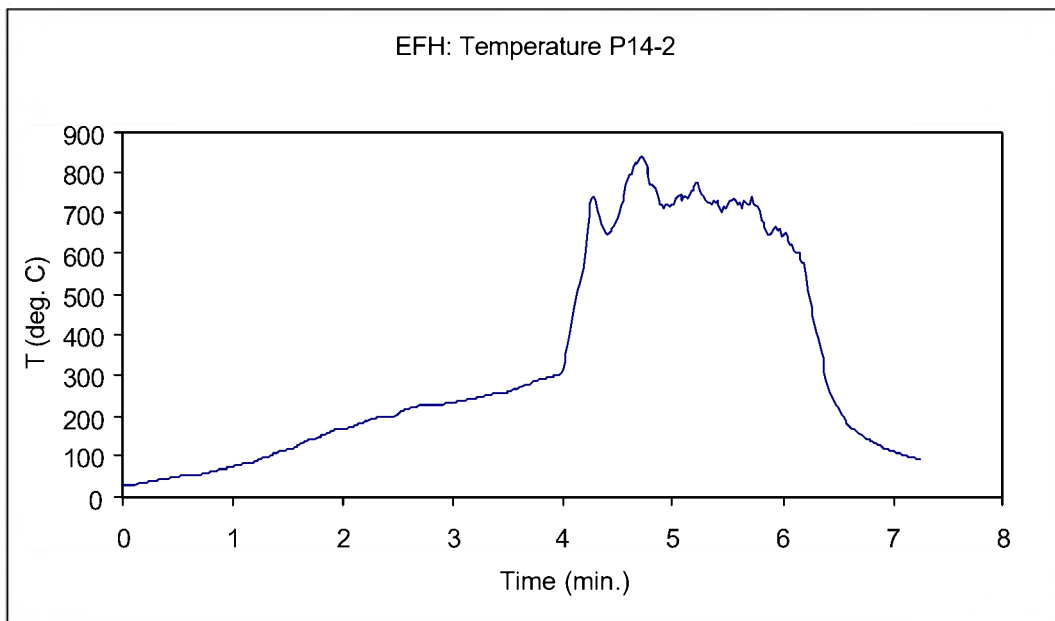

N20 - 1

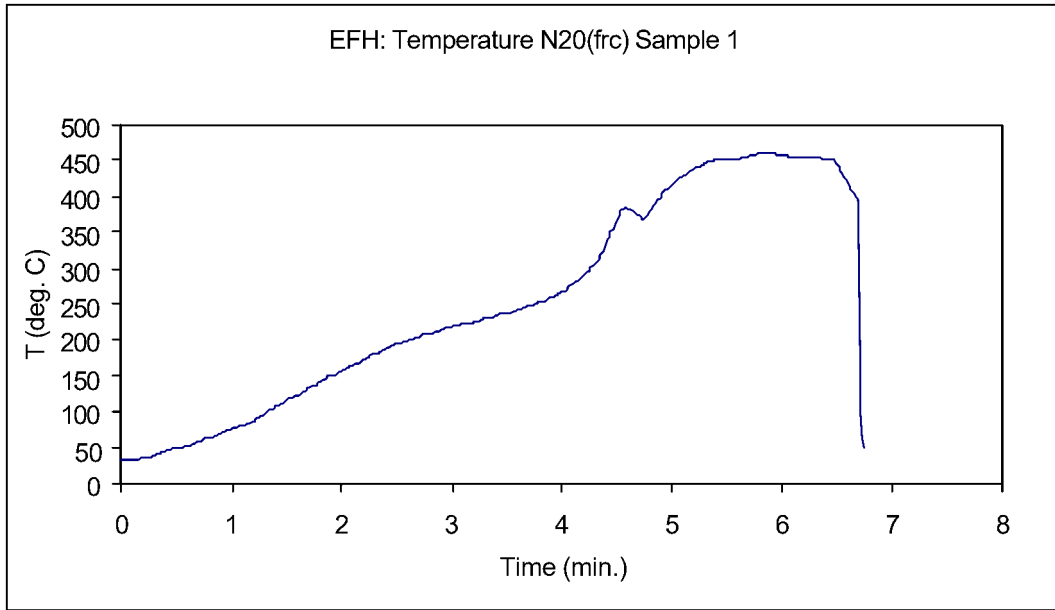

N20 - 2

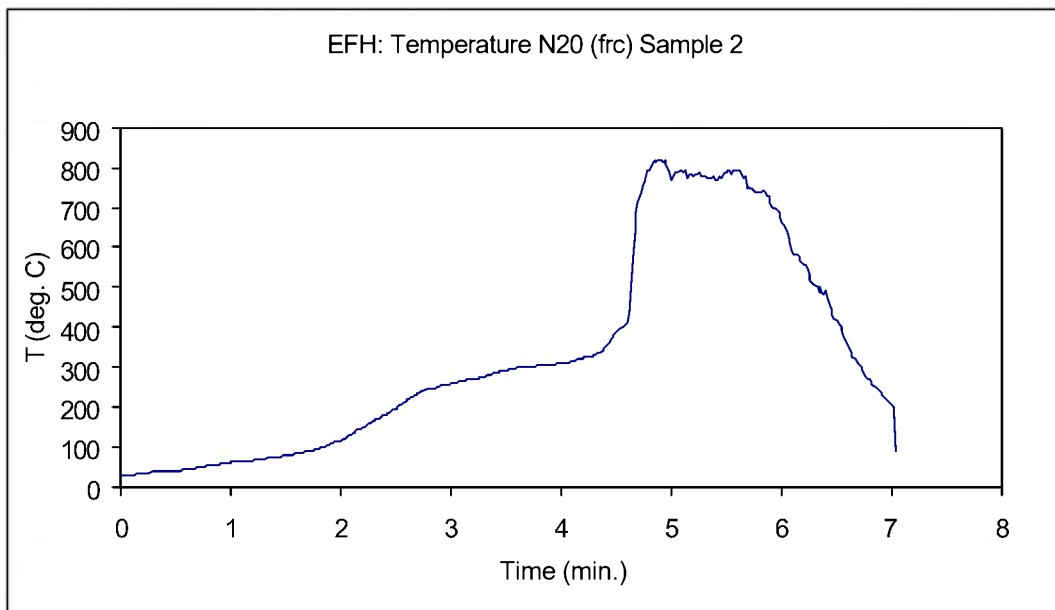

N20 - 3

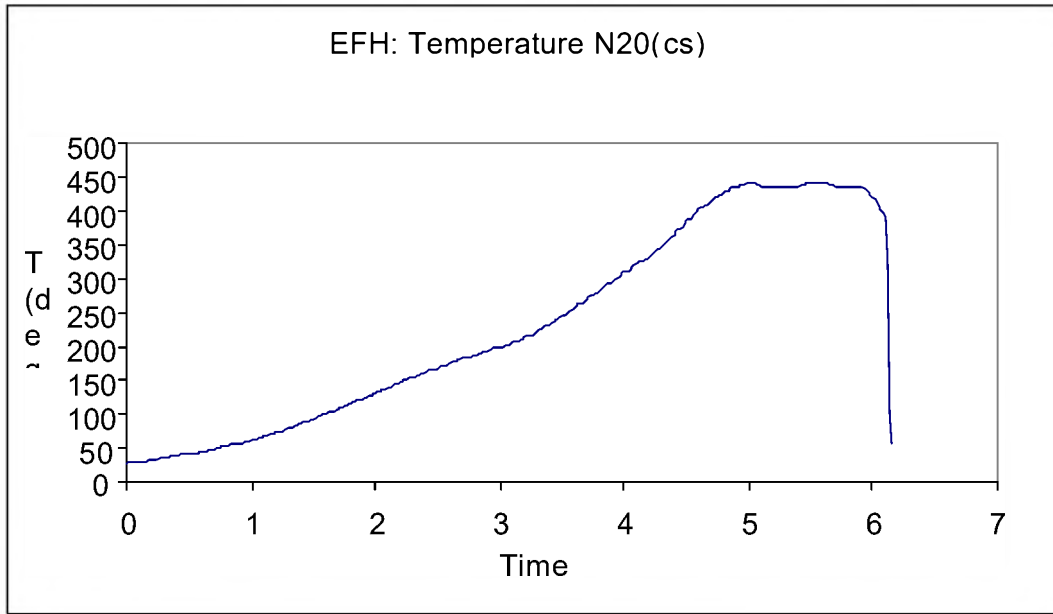

N20 - 4

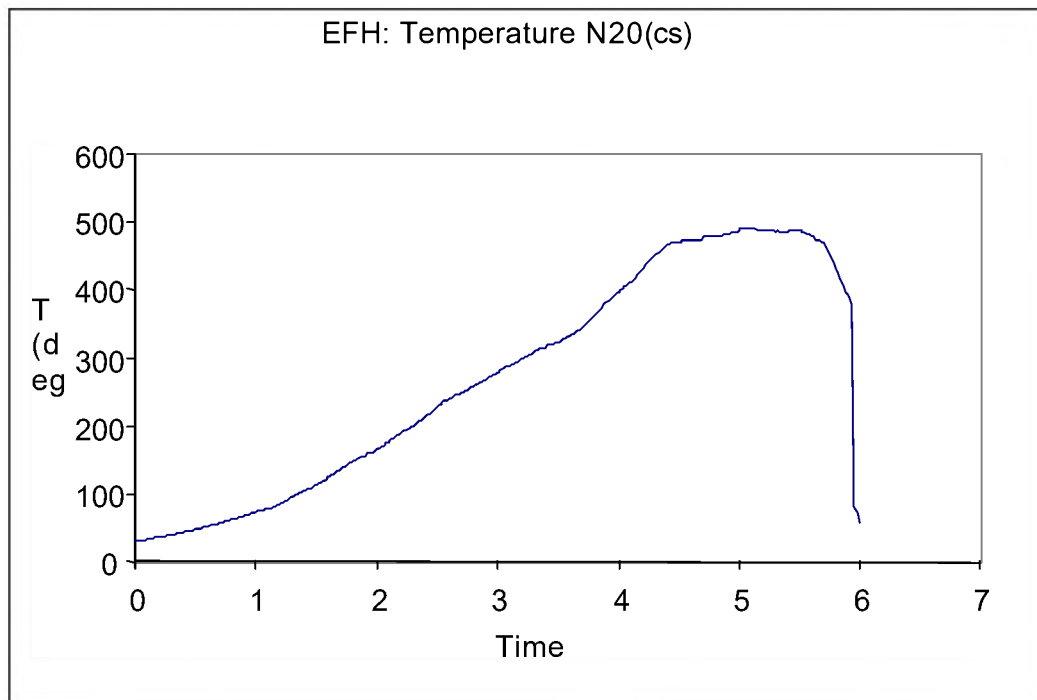

APPENDIX E

Data from Flooring Radiant Panel Tests

Summary of Flooring Radiant Panel test results.

<i>Code</i>	<i>Backing Cement = cement sheet CaSi = calcium silicate board</i>	<i>Mean distance burnt (cm)</i>	<i>Duration of test (sec)</i>	<i>Mean critical radiant flux (kW/m²)</i>	<i>Standard deviation (cm)</i>
RF1-1	Cement	9.7	640	10.73	Not applicable
RF1-2	Cement	8.6	730	10.95	Not applicable
N9-1	Cement	56.4	3440	2.91	Not applicable
N9-2	Cement	54.7	3536	3.11	Not applicable
N20-1	Cement	27.3	600	7.36	Not applicable
N20-2	Cement	26.6	660	7.48	Not applicable
N20-3	CaSi	25.4	600	7.70	Not applicable
N20-4	CaSi	31.9	600	6.15	Not applicable
P14-1	Cement	100.5	3588	0.79	Not applicable
P14-2	Cement	107.0	3588	0.71	Not applicable
W2b-1	Cement	25.0	687	7.87	Not applicable
W2b-2	Cement	22.0	700	8.47	Not applicable
<i>From previous experiments:</i>					
W2B	CaSi	26.8	Not available	7.6	10.6
W5	CaSi	17.8	Not available	9.5	5.35
P6	CaSi	98.5	Not available	<1.0	5.2
P14	CaSi	82.8	Not available	1.4	4.25
N9	CaSi	50.5	Not available	3.4	5.0
N13	CaSi	49.0	Not available	3.7	8.5
N14	CaSi	46.8	Not available	3.9	2.8

ASTM E648 Flooring Radiant Panel

Sponsor FCRC
 Test Date July 5, 1999
 Test No. R041

Calibration Curve to Determine Critical Radiant Flux

Sensitivity 0.149

mV	mm	kW/m ²
1.57	100	10.54
1.34	200	8.99
1.03	300	6.91
0.77	400	5.17
0.56	500	3.76
0.39	600	2.62
0.29	700	1.95
0.22	800	1.48
0.18	900	1.21

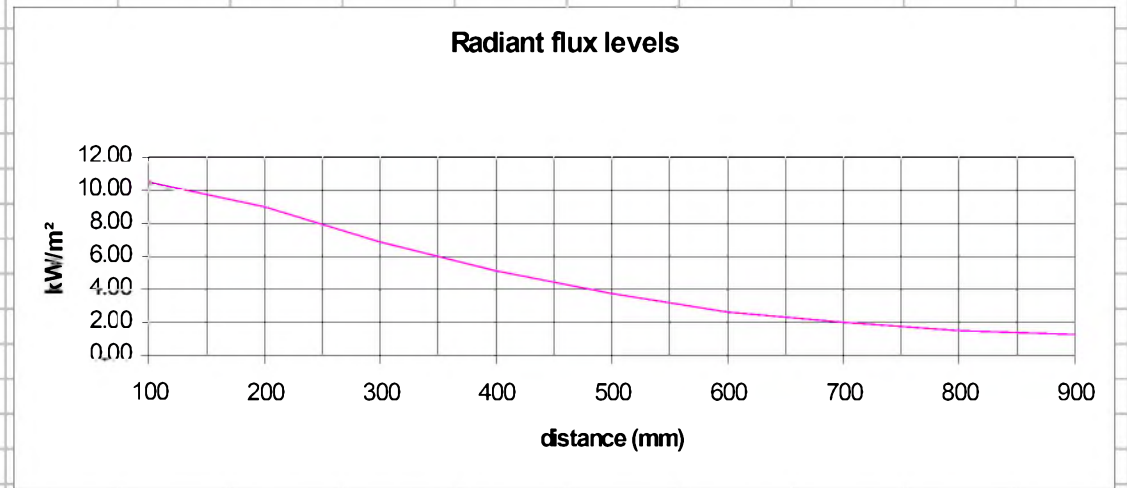

	distance	time	CRF
N20 - cement sheet	273	600	7.36

ASTM E648 Flooring Radiant Panel

Sponsor FCRC
 Test Date July 23, 1999
 Test No. R044

Calibration Curve to Determine Critical Radiant Flux

Sensitivity 0.149

mV	mm	kW/m ²
1.63	100	10.94
1.36	200	9.13
1.04	300	6.98
0.77	400	5.17
0.54	500	3.62
0.4	600	2.68
0.29	700	1.95
0.22	800	1.48
0.18	900	1.21

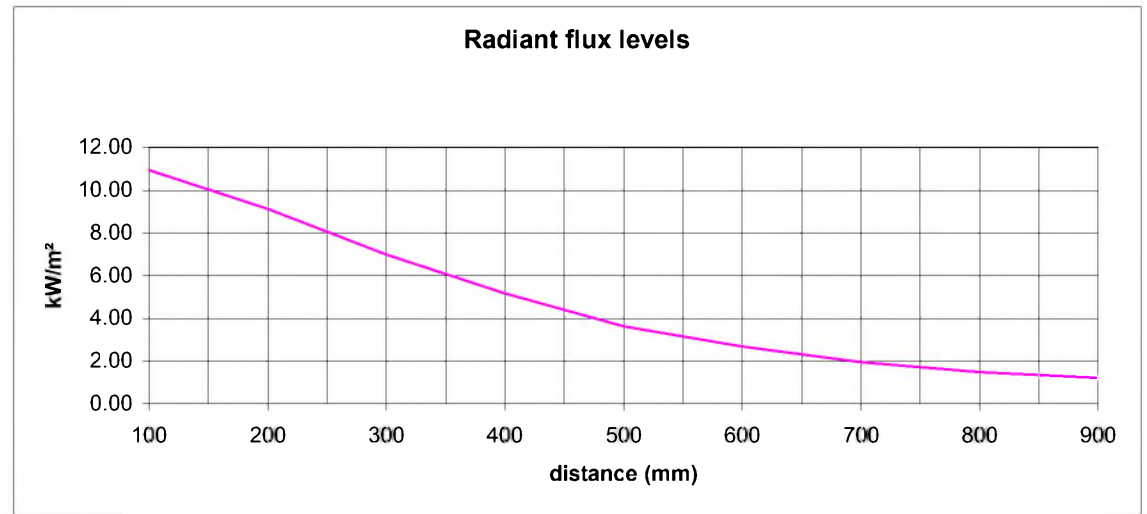

	distance	time	CRF
P14 - cement sheet	1070	3588	0.71
W2b - cement sheet	250	687	7.87
W2b - cement sheet	220	700	8.47

ASTM E648 Flooring Radiant Panel

Sponsor FCRC
 Test Date July 16, 1999
 Test No. R043

Calibration Curve to Determine Critical Radiant Flux

Sensitivity 0.149

mV	mm	kW/m ²
1.66	100	11.14
1.4	200	9.40
1.06	300	7.11
0.77	400	5.17
0.55	500	3.69
0.39	600	2.62
0.29	700	1.95
0.22	800	1.48
0.18	900	1.21

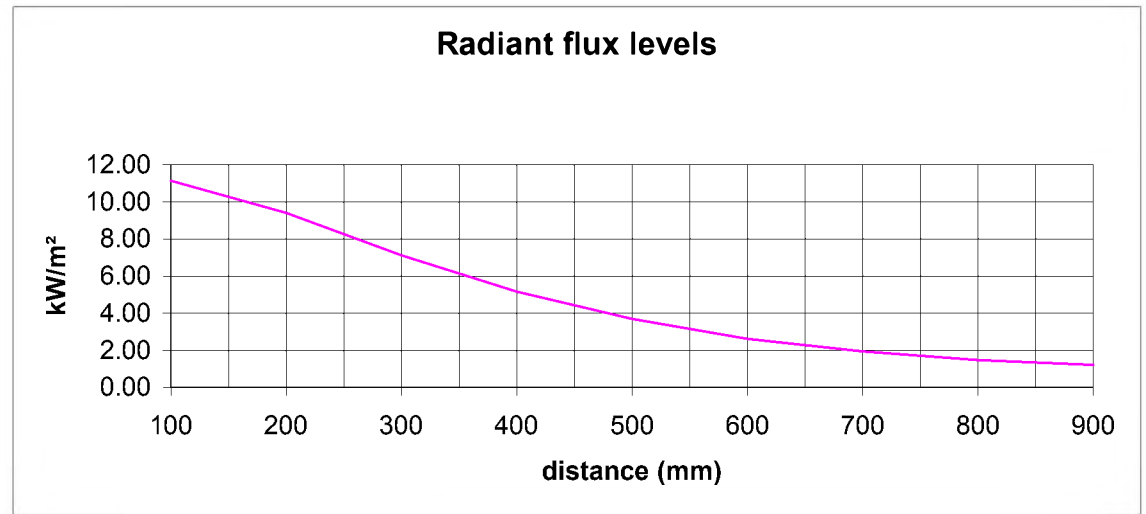

	distance	time	CRF
P14 - cement sheet	1005	3588	0.79

ASTM E648 Flooring Radiant Panel

Sponsor FCRC
 Test Date July 9, 1999
 Test No. R042

Calibration Curve to Determine Critical Radiant Flux

Sensitivity 0.149

mV	mm	kW/m ²
1.57	100	10.54
1.3	200	8.72
1.02	300	6.85
0.77	400	5.17
0.56	500	3.76
0.4	600	2.68
0.3	700	2.01
0.22	800	1.48
0.18	900	1.21

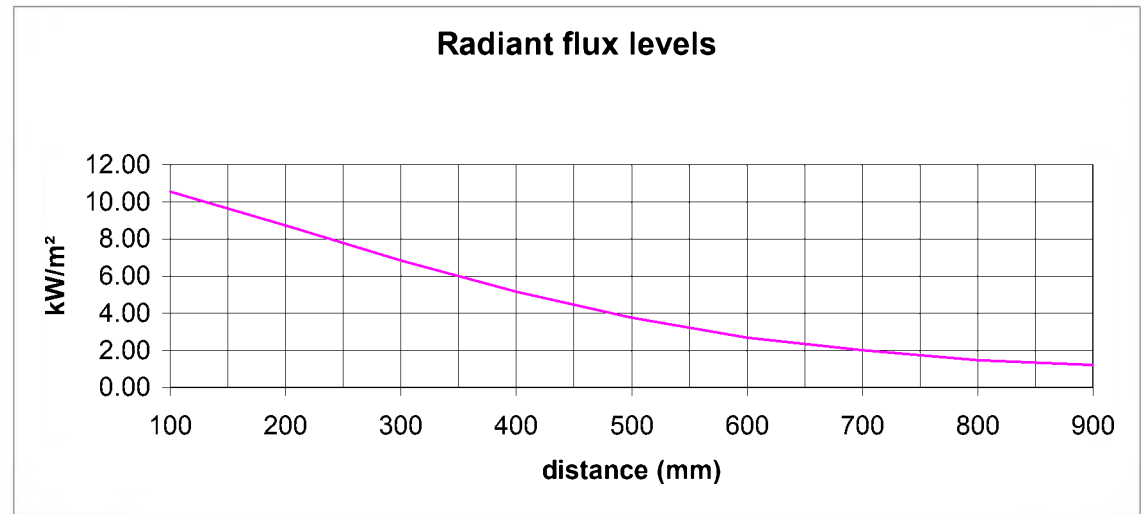

	distance	time	CRF
N9 - cement sheet	564	3440	2.91
N9 - cement sheet	547	3536	3.11

ASTM E648 Flooring Radiant Panel

Sponsor FCRC
 Test Date July 5, 1999
 Test No. R041

Calibration Curve to Determine Critical Radiant Flux
 Sensitivity 0.149

mV	mm	kW/m ²
1.57	100	10.54
1.34	200	8.99
1.03	300	6.91
0.77	400	5.17
0.56	500	3.76
0.39	600	2.62
0.29	700	1.95
0.22	800	1.48
0.18	900	1.21

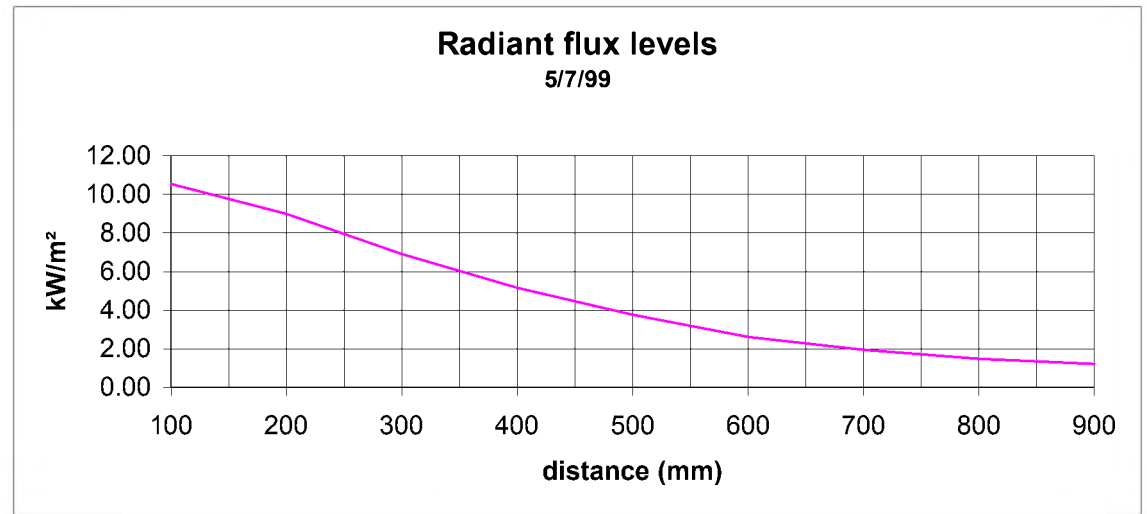

	distance	time	CRF
N20 - cement sheet	273	600	7.36
N20 - cement sheet	266	660	7.48
N20 - calcium silicate board	254	600	7.70
RF1 - cement sheet	97	640	10.73
RF1 - cement sheet	86	730	10.95

FCRC Project 2 Stage B Cone Tests

APPENDIX F



Procedure

1. In tests where surface temperature was measured, a thermocouple connected to a dataker was used.
2. Data was normally logged using the Cone software and these files were aligned with the dataker files where required.
3. When temperature is measured it is believed that the mass data is unreliable as we have no way of knowing the effect a thermocouple by its mass and location has on the specimen mass loss during testing.

TEST A

Tests were done until ignition was reached. Time v Temperature to ignition was recorded.
 Atmospheric intake air was used (20.95% O2)

Material	Highett Code	No. of tests					
		Irradiance					
		10	15	25	35	50	60
100% Wool (W2B)	180 NI			FC180A25		FC180A50	FC180A60
				FC180B25		FC180B50	FC180B60
						FC180C50	FC180C60
100% Polyamide (N9)	179			FC179A25		FC179A50	FC179B60
				FC179B25		FC179B50	FC179C60
						FC179C50	FC179D60
						FC179D50	
PVC Flooring (RF1)	181			FC181A25		FC181A50	FC181A60
				FC181B25		FC181B50	FC181B60
						FC181C50	FC181C60
Nylon (N20)	178			FC178A25		FC178A50	FC178A60
				FC178B25		FC178B50	FC178B60
				FC178C25		FC178C50	FC178C60

 Tests not required
 Surface thermocouple used

Test B - Standard Cone Test (Ambient Air)

Material	Highett Code	No. of tests					
		Irradiance					
		10	15	25	35	50	60
100% Wool (W2B)	180			FC180A15		FC180A35	
				FC180B15		FC180B35	
						FC180D35	
						FC180E35	
						FC180F35	
						FC180G35	
100% Polyamide (N9)	179			FC179A15		FC179A35	
				FC179B15		FC179B35	
				FC179C15		FC179C35	
						FC179D35	
						FC179E35	
						FC179F35	
PVC Flooring (RF1)	181			FC181A15		FC181A35	
				FC181C15		FC181B35	
						FC181C35	
						FC181D35	
						FC181E35	
						FC181F35	
Nylon (N20)	178			FC178A15		FC178A35	
				FC178B15		FC178C35	
				FC178C15		FC178D35	
						FC178E35	
						FC178F35	
						FC178G35	

Test C - Standard Cone Test (Nitrogen Pyrolysis)

Material	Highett Code	No. of tests					
		Irradiance					
		10	15	25	35	50	60
100% Wool (W2B)	180		F180A15Z		F180B35Z		
			F180B15Z		F180C35Z		
100% Polyamide (N9)	179		F179A15Z		F179A35Z		
			F179B15Z		F179B35Z		
PVC Flooring (RF1)	181		F181A15Z		F181A35Z		
			F181C15Z		F181B35Z		
Nylon (N20)	178		F178C15Z		F178G35Z		
			F178E15Z		F178H35Z		

FCRC Project 2b - Cone calorimeter test results

Test A	Material	Specimen No.	Irradiance (kW/m ²)	Ignition time (s)
FC178A25	N20	178	25	44
FC178B25	N20	178	25	50
FC178C25	N20	178	25	45
FC178A50	N20	178	50	14
FC178B50	N20	178	50	14
FC178C50	N20	178	50	14
FC178A60	N20	178	60	12
FC178B60	N20	178	60	10
FC178C60	N20	178	60	11
FC179A25	N9	179	25	136
FC179B25	N9	179	25	136
FC179B50	N9	179	50	33
FC179C50	N9	179	50	31
FC179D50	N9	179	50	36
FC179A60	N9	179	60	18
FC179B60	N9	179	60	17
FC179C60	N9	179	60	19
FC180A25	W2B	180	25	42
FC180A50	W2B	180	50	5
FC180B50	W2B	180	50	6
FC180C50	W2B	180	50	6
FC180B60	W2B	180	60	3
FC180C60	W2B	180	60	3
FC180D60	W2B	180	60	3
FC181A25	RF1	181	25	70
FC181B25	RF1	181	25	72
FC181A50	RF1	181	50	13
FC181B50	RF1	181	50	14
FC181C50	RF1	181	50	14
FC181A60	RF1	181	60	8
FC181B60	RF1	181	60	11
FC181C60	RF1	181	60	10

Test A stopped at ignition. Surface temperature was measured for most of these tests.

CSIRO Fire Science and Technology Laboratory

Test B

Test No	Material	Surface thermocouple	Irradiance	End of test (s)	Ignition time (s)	End of test (s)	Specimen Mass (g)	Mass remaining (g)	Ave Mass loss rate (g/m ² s)	Effective area (mm ²)*10 ⁴	Total heat Evolved (kJ)	Peak RHR (kW/m ²)	Time of Peak RHR (s)	RHR (kW/m ²) from start of test			THE in First 300s (MJ/kg) ^b	Average EHC (MJ/kg) ^b	Average SEA (m ² /kg) ^a	Carbon Monoxide (kg/kg) ^a	CO Total (g) ^a	Carbon Dioxide (kg/kg) ^a	CO ₂ Total (g)	
														60 s av ^b	180 s av ^b	300 s av ^b								
FC178A15	N20		15	565	500	565	168.3	164.2981	0.008983	0.88	9.818512	17.336	565	12.75267	-	-	8.243048	1.44172	742.9757	0.001157	0.004629	0.076881	0.307671	
FC178B15	N20		15	305	185	305	165.2	160.4551	0.034508	0.88	58.56893	132.884	220	68.25042	-	-	56.9807	6.605827	799.0112	0.01534	0.072786	0.3258	1.545887	
FC178C15	N20		15	65	No ign.	65	158.2	158.0497	0.004555	0.88	0.50776	1.166	65	0.8645	-	-	0.50776	3.126673	272.1635	0.000075	1.13E-05	0.100785	0.015148	
FC178F35	N20		35	465	26	465	169.6	151.555	0.047549	0.88	282.7154	445.542	40	228.5178	112.4213	94.6801	249.9555	14.56126	237.7358	0.033875	0.611274	1.053332	19.00738	
FC178A35	N20		35	185	24	185	171.1213	161.0003	0.080008	0.88	177.4507	435.125	40	224.821	-	-	177.0143	16.19016	463.3862	0.041884	0.423904	0.992023	10.04026	
FC178C35	N20		35	355	25	355	157.1	140.1401	0.062931	0.88	297.0367	454.458	40	235.6164	137.5277	108.9731	287.6889	17.80209	266.8563	0.026682	0.45252	0.977062	16.57088	
FC178D35	N20		35	415	25	415	158.1026	140.9707	0.052795	0.88	265.9928	430.628	40	233.0258	123.4423	96.31245	254.2649	13.77716	234.4812	0.028848	0.494225	0.788168	13.50282	
FC178E35	N20		35	180	26	180	169.0067	158.8726	0.102365	0.88	157.0729	472.936	40	230.3712	-	-	155.3308	12.96825	477.3093	0.046885	0.475134	0.875379	8.871181	
FC178G35	N20		35	480	29	480	169.5	151.5017	0.04545	0.88	260.9684	492.207	45	223.9736	102.9083	84.79105	223.8484	12.94188	163.1231	0.038367	0.690532	0.952536	17.14402	
FC179A15	N9		15	750	370	750	94.1	73.6283	0.052424	0.88	361.8133	197.571	430	127.0338	152.0557	123.1613	325.1458	10.22712	250.4441	0.012923	0.264558	0.681828	13.95817	
FC179B15	N9		15	690	225	690	129.0149	91.3176	0.065277	0.88	310.3749	118.956	385	52.12033	88.83758	88.49055	233.6151	12.13121	400.6823	0.012136	0.457503	1.009393	38.05137	
FC179C15	N9		15	795	490	795	93.9	74.4291	0.043706	0.88	330.6495	233.388	555	135.1818	159.7988	124.2126	327.9211	7.848803	288.6114	0.007708	0.150074	0.525203	10.22617	
FC179A35	N9		35	585	63	585	91.8	64.4237	0.064643	0.88	451.1445	408.149	95	295.9978	192.9841	145.3857	383.8183	13.21085	98.40794	0.024822	0.679533	0.741039	20.28691	
FC179C35	N9		35	555	70	555	92.4652	64.8137	0.073934	0.88	455.9473	337.767	105	234.5004	192.8917	148.9919	393.3386	12.99143	954.2184	0.025417	0.702826	1.057165	29.23219	
FC179D35	N9		35	600	70	600	94.6502	67.2421	0.06557	0.88	431.1347	397.314	105	269.4701	192.0421	143.4708	378.763	11.38581	894.5478	0.034643	0.949499	0.958978	26.28376	
FC179E35	N9		35	605	73	605	93.1	64.5475	0.065713	0.88	436.1327	398.969	100	305.9484	195.5452	144.0388	380.2623	11.67933	145.9128	0.031453	0.898049	0.871883	24.89444	
FC179F35	N9		35	595	70	595	91.5	64.0532	0.064809	0.88	425.2176	367.693	105	268.5961	192.2754	141.5391	373.6632	11.78595	133.1864	0.033097	0.908418	0.903126	24.78793	
FC179G35	N9		35	570	73	570	90.1	63.4438	0.067314	0.88	433.0785	417.249	105	320.8618	193.6575	146.4599	386.654	12.35191	156.2273	0.033288	0.887331	0.955671	25.47456	
FC179B35	N9		35	ERROR																				
FC181A15	RF1		15	370	305	370	93.5	88.6681	0.019523	0.88	8.883688	16.182	330	12.41283	-	-	7.864604	1.332588	274.4726	0.003552	0.017164	0.091233	0.44083	
FC181C15	RF1		15	ERROR																				
FC181A35	RF1		35	ERROR																				
FC181B35	RF1		35	580	32	580	92.1	68.8009	0.050431	0.88	283.3869	131.811	40	98.88208	84.45208	74.99733	197.993	12.30912	196.7609	0.037881	0.882603	0.677834	15.79292	
FC181C35	RF1		35	615	32	615	93.3	68.3069	0.051058	0.88	274.1433	133.947	45	93.01917	80.97903	72.97178	192.6455	10.66055	189.7069	0.046304	1.157282	0.612439	15.30674	
FC181D35	RF1		35	575	31	575	86.9	61.8304	0.055587	0.88	294.6453	143.718	35	95.47983	89.55917	82.1462	216.866	11.42472	236.5334	0.049711	1.246235	0.968001	24.08691	
FC181E35	RF1		35	595	31	595	92.1	66.533	0.053432	0.88	298.4475	151.738	35	101.0813	89.31281	82.69327	218.3102	11.34911	198.9553	0.052986	1.354681	0.937405	23.96665	
FC181F35	RF1		35	565	32	565	92.1	66.83	0.056723	0.88	284.6256	135.504	40	94.076	96.03933	84.0124	221.7927	10.75627	228.0617	0.055651	1.406313	0.87592	22.13451	
FC180A15	W2B		15	65	No ign.	65	95.7	95.4185	0.010573	0.88	0	0	5	-	-	-	0	0	31.57754	0.000022	1.28E-05	0.029108	0.016926	
FC180B15	W2B		15	65	No ign.	65	95.7	95.0856	0.011171	0.88	0	0	5	-	-	-	0	0.00132	33.24285	1.57E-05	9.64E-06	0.027226	0.016728	
FC180A35	W2B		35	580	17	580	96.5	72.69	0.047572	0.88	401.6837	259.269	30	154.9436	104.0652	104.7704	276.5939	17.13957	145.811	0.017749	0.422593	1.105281	26.31673	
FC180B35	W2B		35	630	13	630	97.8708	73.4036	0.046339	0.88	396.4778	267.508	30	136.8422	85.67189	94.79848	250.268	15.57133	140.4097	0.019756	0.483379	0.96804	23.68523	
FC180D35	W2B		35	630	13	630	100.5031	76.6414	0.046154	0.88	390.3674	268.006	30	149.4111	94.21147	96.65523	255.1698	16.93048	127.9309	0.021232	0.506635	0.968999	23.12197	
FC180E35	W2B		35	620	13	620	96.8	70.9302	0.047996	0.88	393.7325	261.908	30	144.2892	86.61442	93.91715	247.9413	14.75517	169.8894	0.019607	0.507237	1.10966	28.69115	
FC180F35	W2B		35	640	17	640	97.5	71.9006	0.046544	0.88	396.5859	271.578	30	152.6191	92.24858	91.44545	241.416	15.31248	141.2432	0.016693	0.427331	1.175063	30.08092	
FC180G35	W2B		35	620	17	620	97	71.1922	0.049393	0.88	398.6161	265.755	30	150.5352	95.1705	98.34718	259.6366	14.92772	178.3372	0.020466	0.528192	1.156066	29.83551	

* Note - ERROR indicates an error associated with measuring mass loss preventing calculation of mass dependant properties.

From previous experiments:		Radiation level kW	Ignition time s	Total heat evolved kJ	RHR* peak kW/m ²	Time to peak RHR* s	RHR from ignition average over			Average Specific extinction area m ² /kg	RHR at 35 kW/m ² from start of test average over		
Carpet code							100s kW/m ²	200s kW/m ²	300s kW/m ²		100s kW/m ²	200s kW/m ²	300s kW/m ²
	W2B	25	49	36.9	121.4	65	60.8	na	na	129.6			
	W2B	35	16	440.1	277.9	30	164.5	101.7	89.3	103.7	94.3	85.4	88.6
	W2B	50	6	505.6	385.7	20	208.5	164.8	146.4	133.2			
	W5	25	39	183.1	211.9	51.7	112.3	61.3	50.7	92.6			
	W5	35	14	470.3	268	28.3	175.8	146.3	122	100.1	136.3	120.6	109.3
	W5	50	6	511.8	347.7	15	239.9	193.1	154	142.9			
	P6	25	73	496.2	211.8	226.7	126.1	168.9	154.6	394			
	P6	35	35	545.4	291.4	101.7	208.4	230.2	180.3	209.5	198.7	171.9	146.3
	P6	50	17	601.1	447.4	85	355.3	289	211.6	209.6			
	P14	25	64	589.5	251.2	210	154.3	200.1	173.5	504.2			
	P14	35	38	605.6	303	133.3	224.8	241.8	189	184.9	206	178.5	154.9
	P14	50	19	650.7	510.3	66.7	389	305.2	220.1	184.6			
	N9	25	124	537.1	335	153.3	249.5	199.2	153.6	162.7			
	N9	35	71	510.3	423.4	100	318.3	206.9	154.5	131.1	160.5	139.3	120.7
	N9	50	31	531.3	580.2	65	403.7	233.5	169	109.3			
	N13	25	133	425.3	229.8	186.7	170.1	170.9	137.3	315.2			
	N13	35	55	439.1	334.7	95	270.5	194.8	146.4	139.4	158.5	134.7	117.1
	N13	50	23	475	482.6	53.3	375.1	232.7	169.9	132.6			
	N14	25	344	491.1	316	400	168.2	201.1	162.4	234			
	N14	35	65	486	403.9	103.3	277.7	211.6	160.8	192.3	161.8	145.8	127.9
	N14	50	26	506.4	485.6	62.5	379.9	252.9	183.1	169.8			

CSIRO Fire Science and Technology Laboratory

Test C

Note - Mass loss criteria was not met so EOT could not be determined

- Oxygen consumption calorimetry does not apply for zero oxygen tests.

Test No	Material	Irradiance	Ignition time (s)	Specimen Mass (g)	Mass remaining (g)	Ave Mass loss rate (g/m ² s)	Effective area (mm ²)*10 ⁴	Average SEA (m ² /kg) ^a	Carbon Monoxide (kg/kg) ^a	CO Total (g) ^a	Carbon Dioxide (kg/kg) ^a	CO ₂ Total (g)
F178C15Z	N20	15	No ign.	170.3	170.0995	0.004051	0.88	222.6424	0.000211	4.24E-05	0.087601	0.017564
F178E15Z	N20	15	No ign.	170.5	170.3735	0.002875	0.88	341.8184	0.00025	3.16E-05	0.116164	0.014695
F178G35Z	N20	35	No ign.	125.2	115.6421	0.056058	0.88	1652.598	0.001101	0.010519	0.00841	0.080385
F178H35Z	N20	35	No ign.	170.5424	170.4124	0.011818	0.88	75.65708	2.12E-05	2.76E-06	0.018755	0.002438
F179A15Z	N9	15	No ign.	107.5055	107.3283	0.00443	0.8	40.469	0.000246	4.35E-05	0.101287	0.017948
F179B15Z	N9	15	No ign.	94.6	94.3863	0.004317	0.88	20.57254	0.000269	5.75E-05	0.103167	0.022047
F179A35Z	N9	35	No ign.	92.9	92.4749	0.009661	0.88	233.1377	9.62E-05	4.09E-05	0.036341	0.015449
F179B35Z	N9	35	No ign.	92.1	91.6486	0.009119	0.88	292.0568	0.000091	4.11E-05	0.036342	0.016405
F180A15Z	W2B	15	No ign.	96.1	95.4145	0.013848	0.88	88.983	6.75E-05	4.63E-05	0.026481	0.018153
F180B15Z	W2B	15	No ign.	97.3	96.7429	0.011255	0.88	44.90508	7.69E-05	4.29E-05	0.030982	0.01726
F180B35Z	W2B	35	No ign.	97.6	82.3081	0.035645	0.88	997.2482	0.009344	0.142884	0.00939	0.143595
F180C35Z	W2B	35	No ign.	97.3	87.7533	0.041328	0.88	1128.034	0.005593	0.053392	0.009221	0.08803
F180D35Z	W2B	35	No ign.	97.5	78.7263	0.035759	1	838.5785	0.005741	0.107781	0.02477	0.465029
F181A15Z	RF1	15	No ign.	93.3141	93.2233	0.001834	0.88	91.88915	0.000766	6.96E-05	0.27797	0.02524
F181C15Z	RF1	15	No ign.	87.0507	86.9953	0.001679	0.88	194.4296	0.012437	0.000689	1.503924	0.083317
F181A35Z	RF1	35	No ign.	91.3	76.2991	0.045457	0.88	915.1434	0.001677	0.025163	0.008375	0.125637
F181B35Z	RF1	35	No ign.	92.1309	77.9215	0.046973	0.88	952.9326	0.005691	0.080867	0.008326	0.11831

Data from Previous Experiments (BCE Doc 98/131)

Early Fire hazard Test – AS 1530 Part 3

4.5 mm cement sheet was used as a backing board in the EFHT.

Early fire hazard test results, in terms of indices:

<i>AS1530.3 Index</i> <i>Carpet code</i>	<i>Ignitability</i> <i>(range 0 - 20)</i>	<i>Spread of flame</i> <i>(range 0 - 10)</i>	<i>Heat evolved</i> <i>(range 0 - 10)</i>	<i>Smoke developed</i> <i>(range 0 - 10)</i>
W2B	15	0	0	3
W5	13	0	1	4
P6	14	7	5	4
P14	16	8	7	5
N9	16	6	5	4
N13 (guidance test)	11	7	5	5
N14	13	7	6	4

Early fire hazard test - raw results:

<i>ASI530.3 results</i>	<i>Ignition time minutes</i>		<i>Flame propa- gation time seconds</i>		<i>Heat release integral kJ/m²</i>		<i>Smoke release log D</i>	
	<i>mean</i>	<i>SE</i>	<i>mean</i>	<i>SE</i>	<i>mean</i>	<i>SE</i>	<i>mean</i>	<i>SE</i>
W2B	5.12	0.26	nil	-	23.2	3.1	-1.490	0.082
W5	6.50	0.22	nil	-	35.1	4.5	-1.049	0.076
P6	5.84	0.37	50.8	10.8	139.3	10.7	-1.015	0.041
P14	4.31	0.14	33.0	2.6	180.7	8.4	-0.644	0.050
N9	4.30	0.10	71.2	7.4	129.7	5.4	-0.955	0.022
N13	Guidance test only.		No statistical information.					
N14	6.67	0.31	50.9	4.2	161.0	7.9	-1.001	0.073

Flooring radiant panel test results.

A piece of 13 mm calcium silicate board goes underneath the specimen and the whole is clamped into place under the specimen holder.

<i>Carpet code</i>	<i>Mean distance burnt (cm)</i>	<i>Mean critical radiant flux (kW/m²)</i>	<i>Standard deviation (cm)</i>
W2B	26.8	7.6	10.6
W5	17.8	9.5	5.35
P6	98.5	<1.0	5.2
P14	82.8	1.4	4.25
N9	50.5	3.4	5.0
N13	49.0	3.7	8.5
N14	46.8	3.9	2.8

Cone calorimeter results.

The backing material in these tests was cement sheet.

Carpet code	Radiation level <i>kW</i>	Ignition time <i>s</i>	Total heat evolved <i>kJ</i>	RHR* peak <i>kW/m²</i>	Time to peak RHR* <i>s</i>	RHR* average over 100s <i>kW/m²</i>	RHR* average over 200s <i>kW/m²</i>	RHR* average over 300s <i>kW/m²</i>	Average specific extinction area <i>m²/kg</i>
W2B	25	49	36.9	121.4	65.0	60.8	na	na	129.6
W2B	35	16	440.1	277.9	30.0	164.5	101.7	89.3	103.7
W2B	50	6	505.6	385.7	20.0	208.5	164.8	146.4	133.2
W5	25	39	183.1	211.9	51.7	112.3	61.3	50.7	92.6
W5	35	14	470.3	268.0	28.3	175.8	146.3	122.0	100.1
W5	50	6	511.8	347.7	15.0	239.9	193.1	154.0	142.9
P6	25	73	496.2	211.8	226.7	126.1	168.9	154.6	394.0
P6	35	35	545.4	291.4	101.7	208.4	230.2	180.3	209.5
P6	50	17	601.1	447.4	85.0	355.3	289.0	211.6	209.6
P14	25	64	589.5	251.2	210.0	154.3	200.1	173.5	504.2
P14	35	38	605.6	303.0	133.3	224.8	241.8	189.0	184.9
P14	50	19	650.7	510.3	66.7	389.0	305.2	220.1	184.6
N9	25	124	537.1	335.0	153.3	249.5	199.2	153.6	162.7
N9	35	71	510.3	423.4	100.0	318.3	206.9	154.5	131.1
N9	50	31	531.3	580.2	65.0	403.7	233.5	169.0	109.3
N13	25	133	425.3	229.8	186.7	170.1	170.9	137.3	315.2
N13	35	55	439.1	334.7	95.0	270.5	194.8	146.4	139.4
N13	50	23	475.0	482.6	53.3	375.1	232.7	169.9	132.6
N14	25	344	491.1	316.0	400.0	168.2	201.1	162.4	234.0
N14	35	65	486.0	403.9	103.3	277.7	211.6	160.8	192.3
N14	50	26	506.4	485.6	62.5	379.9	252.9	183.1	169.8

*RHR = rate of heat release (averaging periods commence at specimen ignition).

na = specimen extinguished prior to 180 seconds.

Averaged rate of heat release for specimens exposed at 35 kW/m²:

<i>Carpet code</i>	<i>RHR from start of test, averaged over 200 s kW/m²</i>	<i>RHR from start of test, averaged over 300 s kW/m²</i>	<i>RHR from start of test, averaged over 400 s kW/m²</i>
W2B	94.3	85.4	88.6
W5	136.3	120.6	109.3
P6	198.7	171.9	146.3
P14	206.0	178.5	154.9
N9	160.5	139.3	120.7
N13	158.5	134.7	117.1
N14	161.8	145.8	127.9

CSIRO 10 metre Fire Test Corridor

10 metre fire test corridor results.

<i>Carpet code</i>	<i>Test No.</i>	<i>Distance burnt (m)</i>
W2B	97/15	4.1
	23	2.8
	24	3.1
	27	2.7
	30	2.6
	35	3.3
W5 (tested as W1)	34	3.0
	36	2.5
	39	3.3
P6 (tested as P2)	28	10(+)
	29	10(+)
P14 (tested as P3)	31	10(+)
	32	10(+)
N9	98/17	10(+)
	98/19	10(+)
N13		not tested
N14 (tested as N1)	33	10(+)
	37	10(+)

10(+) indicates that the specimen was burning with sufficient intensity at the end of the corridor that combustion would have continued had more fuel been available

Summary of results

<i>Test method</i> <i>Carpet code</i>	<i>AS 1530.3- Spread of flame, smoke developed indices</i>	<i>Flooring Radiant Panel Test – CRF (kW/m²)</i>	<i>Cone Calorimeter - RHR average over 300 s. (kW/m²)</i>	<i>CSIRO 10m Corridor – Mean distance burnt (m)</i>
W2B	0,3	7.6	85.5	3.2
W5	0,4	9.5	120.6	2.9
P6	7,4	<1	171.9	10 (+)
P14	8,5	1.4	178.5	10 (+)
N9	6,4	3.4	139.3	10 (+)
N13	7,5	3.7	134.7	not tested
N14	7,4	3.9	145.8	10 (+)

Specimen details

Code	W2B	W5	P6	P14	N9	N13	N14	N20	RF1
Fibre analysis (%) / composition	Wool 100	Wool 99 Residue 1	Polyolefin 88.2 Polyamide 11.8	Polyolefin 100	Polyamide 100	Polyamide 100	Polyamide 100	nylon pile 100	Plasticised PVC, colour pigments & stabilisers 80 Fillers 20
SPM (g/m ²)	501	907	501	499	427	404	573	Total thickness 4.3mm	Nominal thickness 2.0mm
Pile height (mm)	4.2	4.5	4.0	4.1	3.3	3.4	3.9		
Tufts/unit length 100 mm gauge x stitches	38 x 32.5	39.5 x 32.9	39.4 x 47.1	39.2 x 52.6	39.2 x 42.4	39.5 x 39.0	39.8 x 44.4		
Backing analysis (1) Type/mass (g/m ²)	(1) Primary (P) Woven PP 130	(1) Primary (P) Non woven	(1) Primary (P) Woven PP 130	(1) Primary (P) Woven PP 130	(1) Primary (P) Woven PP 130	(1) Primary (P) Woven PP 135	(1) Primary (P) Woven PP 130	Glass-reinforced PVC	
(2) Threads/unit length Warp x weft/cm	Secondary (S) Woven jute. 507 (2) 66 x 64 (P) 59 x 50 (S)	Secondary (S) Woven jute 237 (2) non woven (P) 50 x 39 (S)	Secondary (S) Woven synthetic 187 (2) 95 x 67 (P) 31 x 21 (S)	Secondary (S) Woven jute. 237 (2) 97 x 67 (P) 51x 40 (S)	Secondary (S) PVC Wt not recorded (2) 97 x 65 (P) not woven (S)	Secondary (S) Woven synthetic 187 (2) 100 x 77 (P) 31 x 24 (S)	Secondary (S) Woven synth. 187 (2) 102 x 65 (P) 31x 21 (S)		
Manufacturing method	Tufted	Tufted	Tufted	Tufted	Tufted	Tufted	Tufted		Electrostatic-ally flocced
Texture	Level loop	Level loop	Level loop	Level loop	Level loop	Level loop	Level loop	Sheet	
Total pile mass (g/m ²) ES - estimate CD - chemical	1356 ES	1328 ES	950 CD	950 ES	950 ES	950 ES	950 ES	Total mass 1.90 kg/m ²	Nominal mass 2.8kg/m ²

Critical Heat Flux from Ignition Times

The Critical Heat Flux and the thermal inertia are obtained from the plots of ignition times versus the exposed heat flux, as shown in the figures of this Appendix. These plots include materials that behave as thermally thick and, sometimes, as thermally thin.
[ref. Craig Brescianini]

CSIRO Fire Science and Technology Laboratory
Critical Heat Flux from Ignition Times

Cone Calorimeter

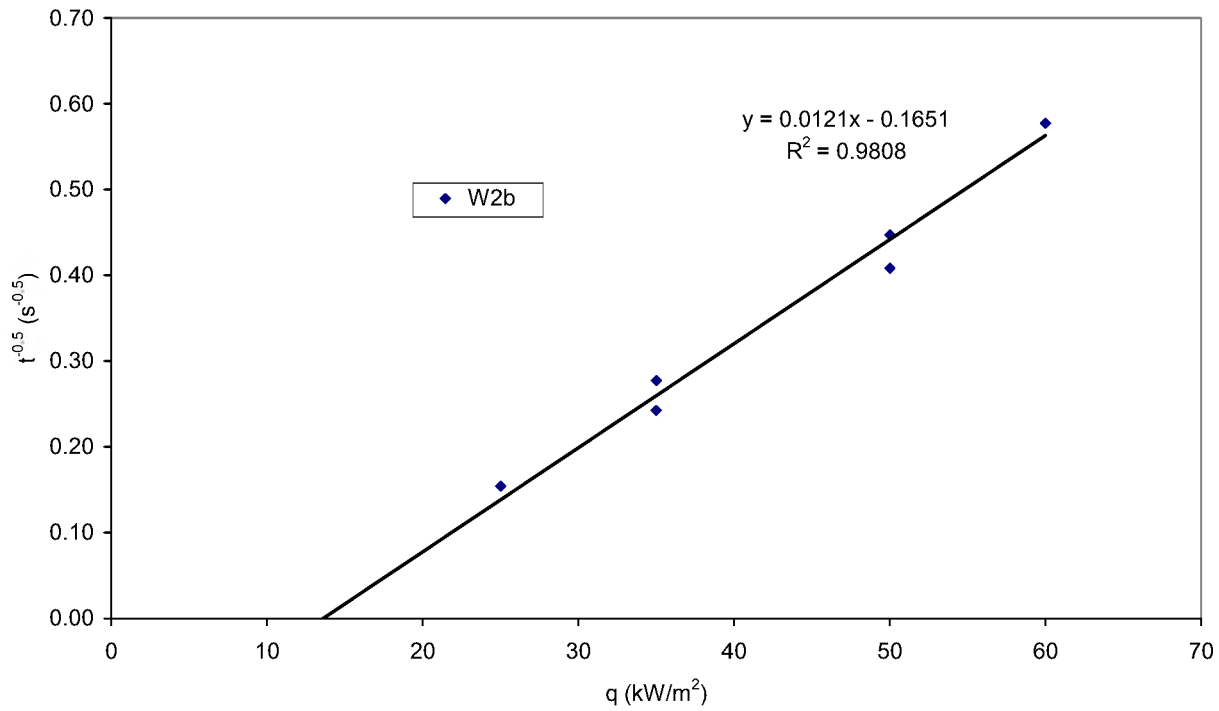

Cone Calorimeter

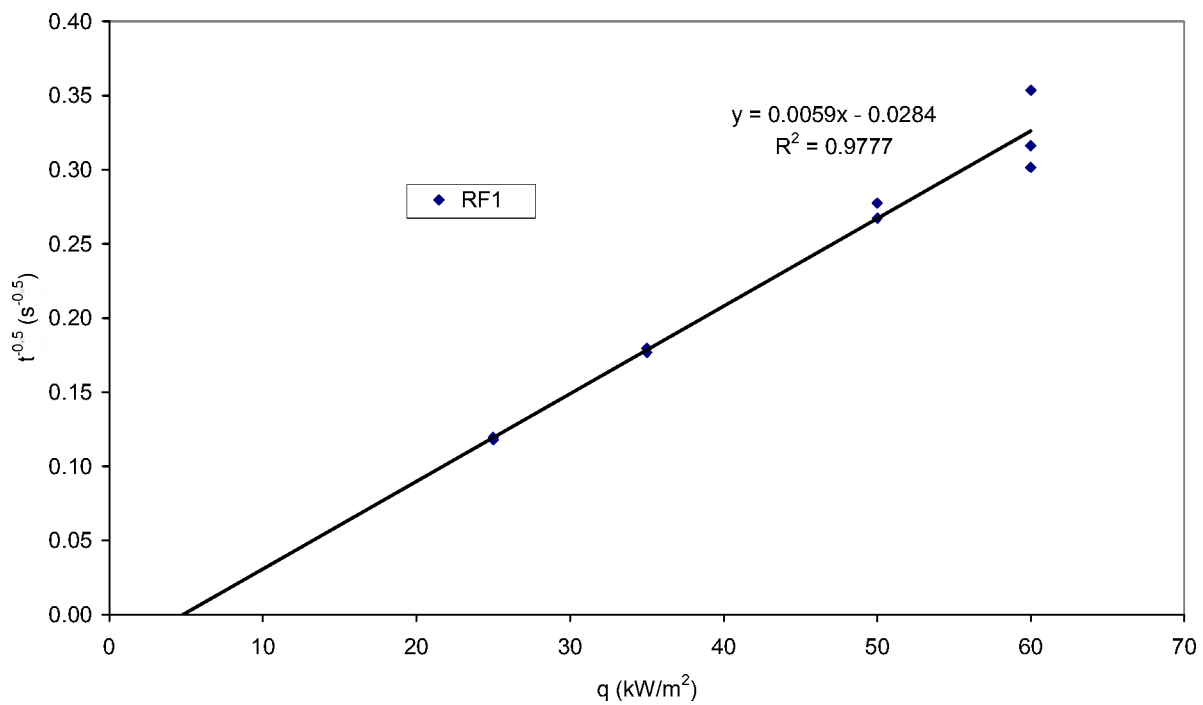

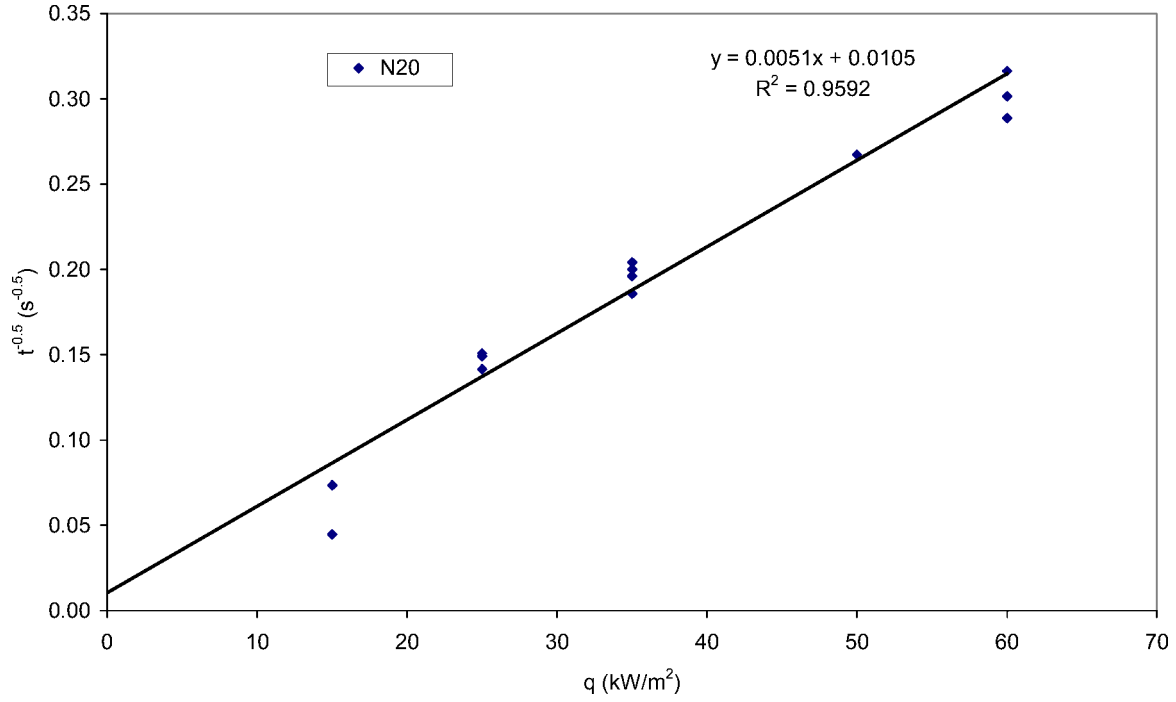

Cone Calorimeter

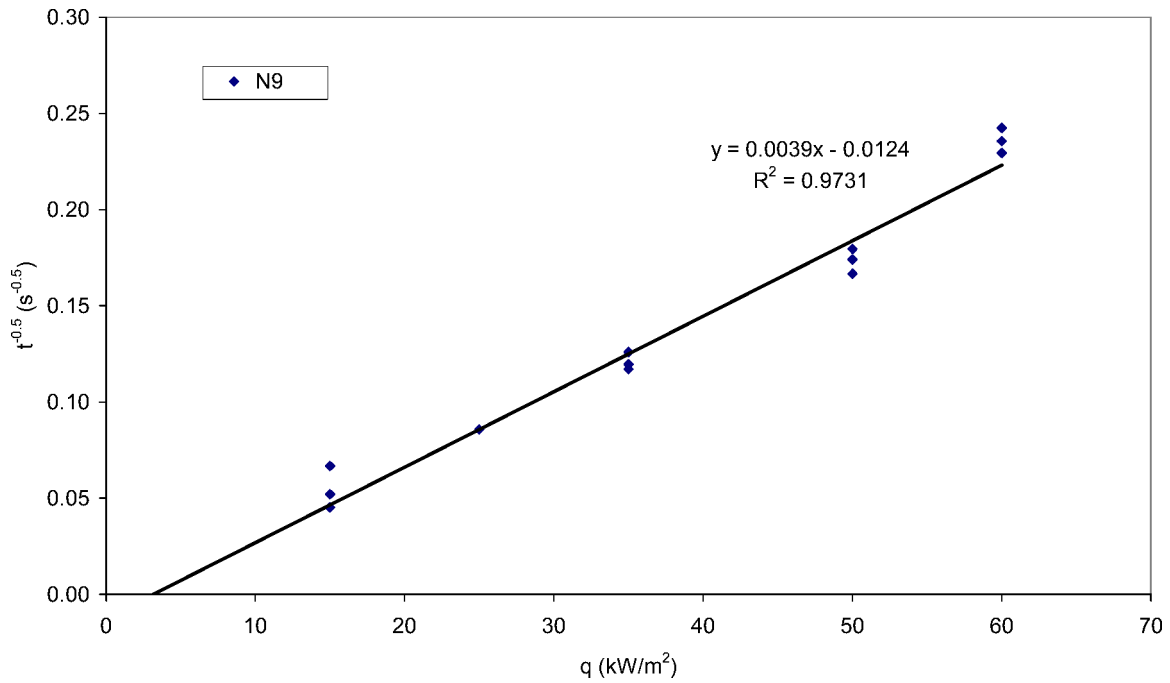

Cone Calorimeter

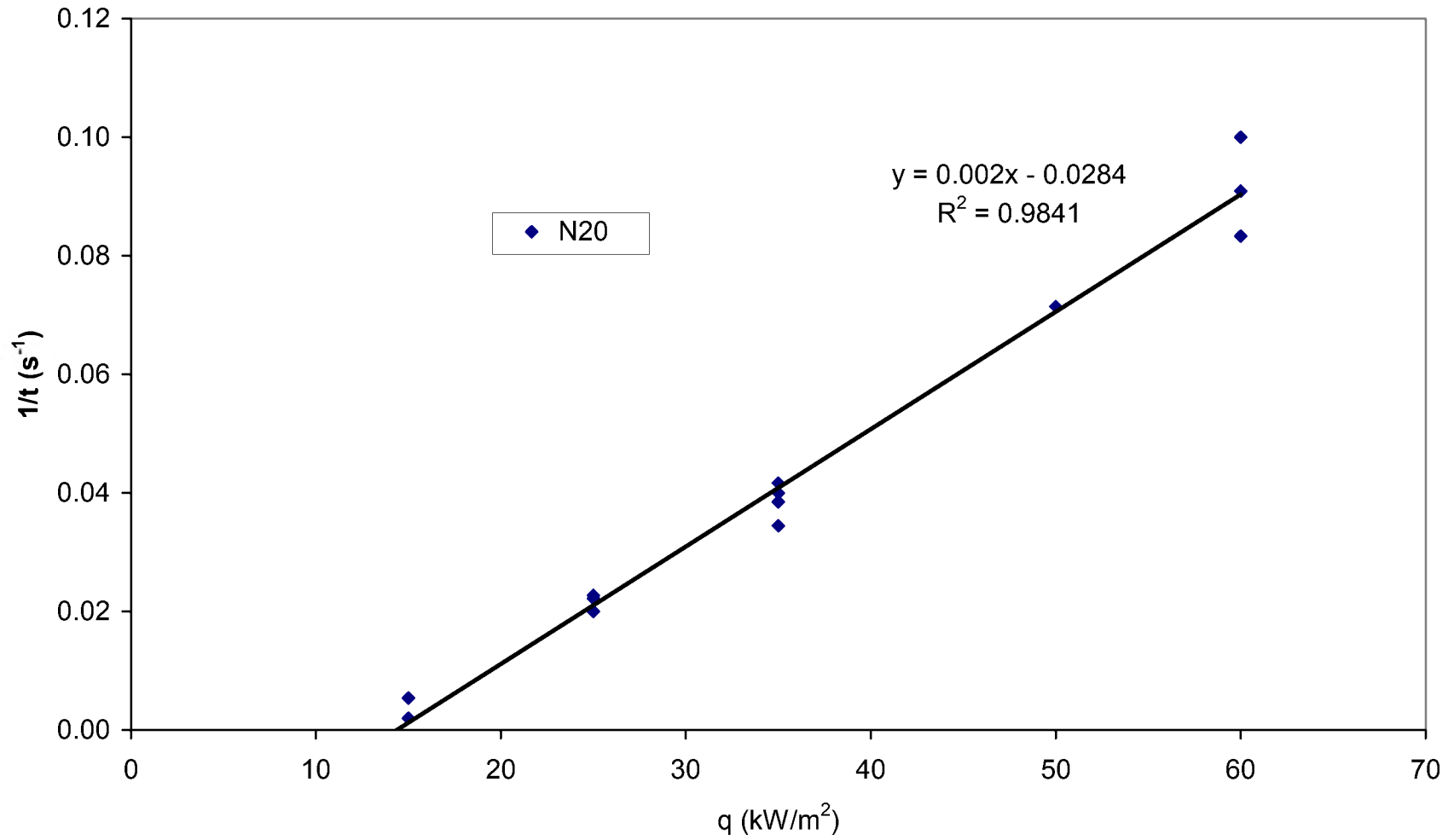

Cone Calorimeter

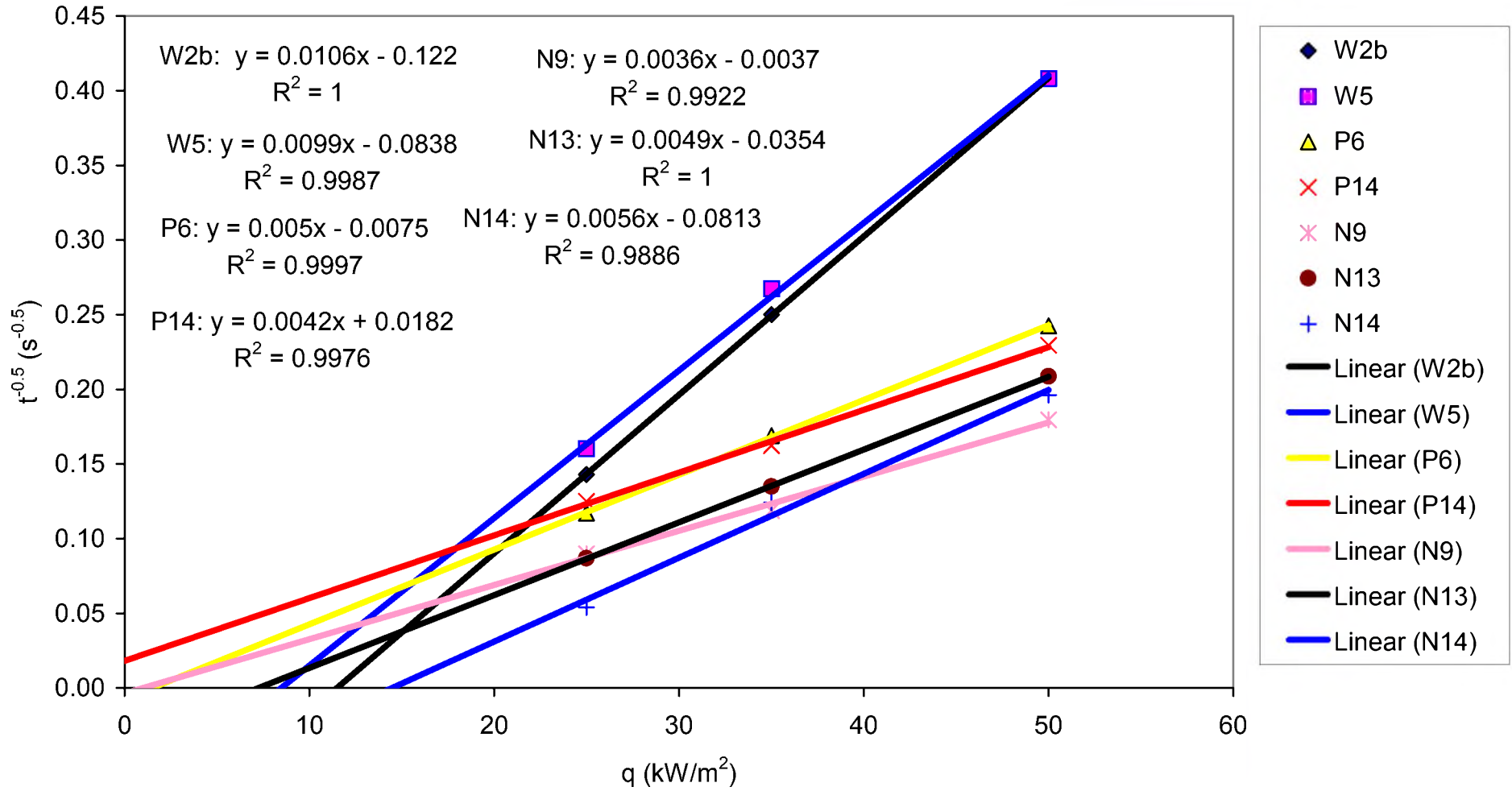

APPENDIX I

Mass Loss and Specific Extinction Area – with and without oxygen

Mass Loss Rate v Time

Cone RF1

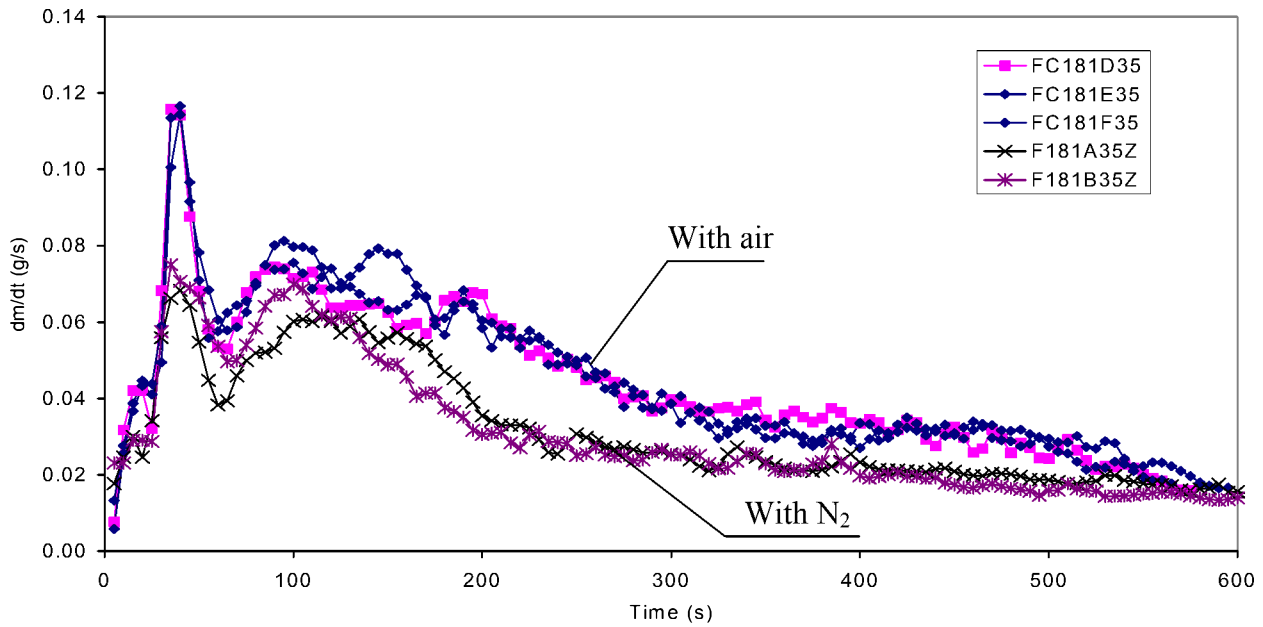

Mass Loss Rate v Time

Cone W2B

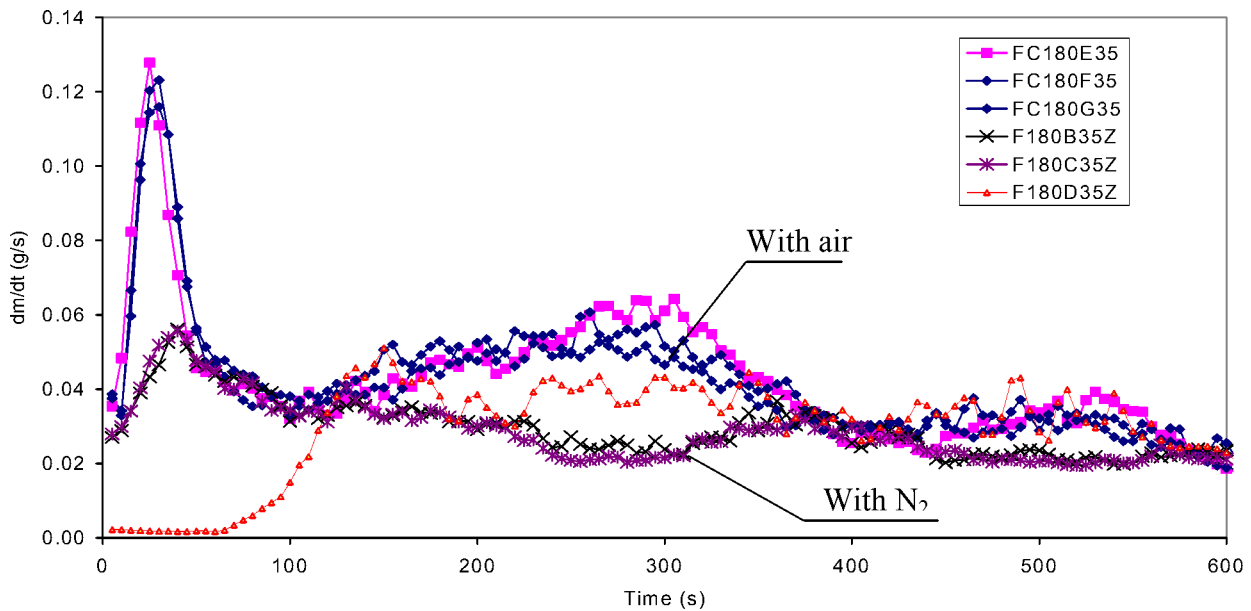

Mass loss rate v time

Cone N20

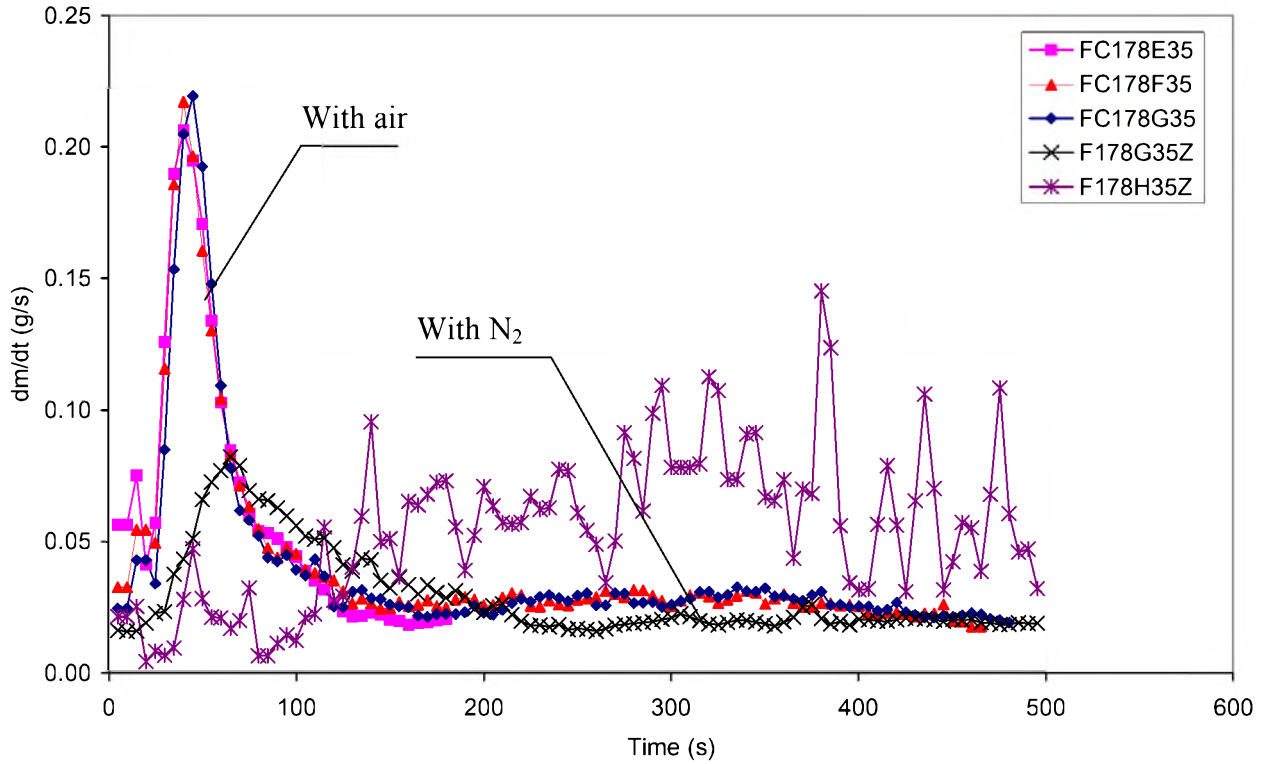

Mass Loss Rate v Time

Cone N9

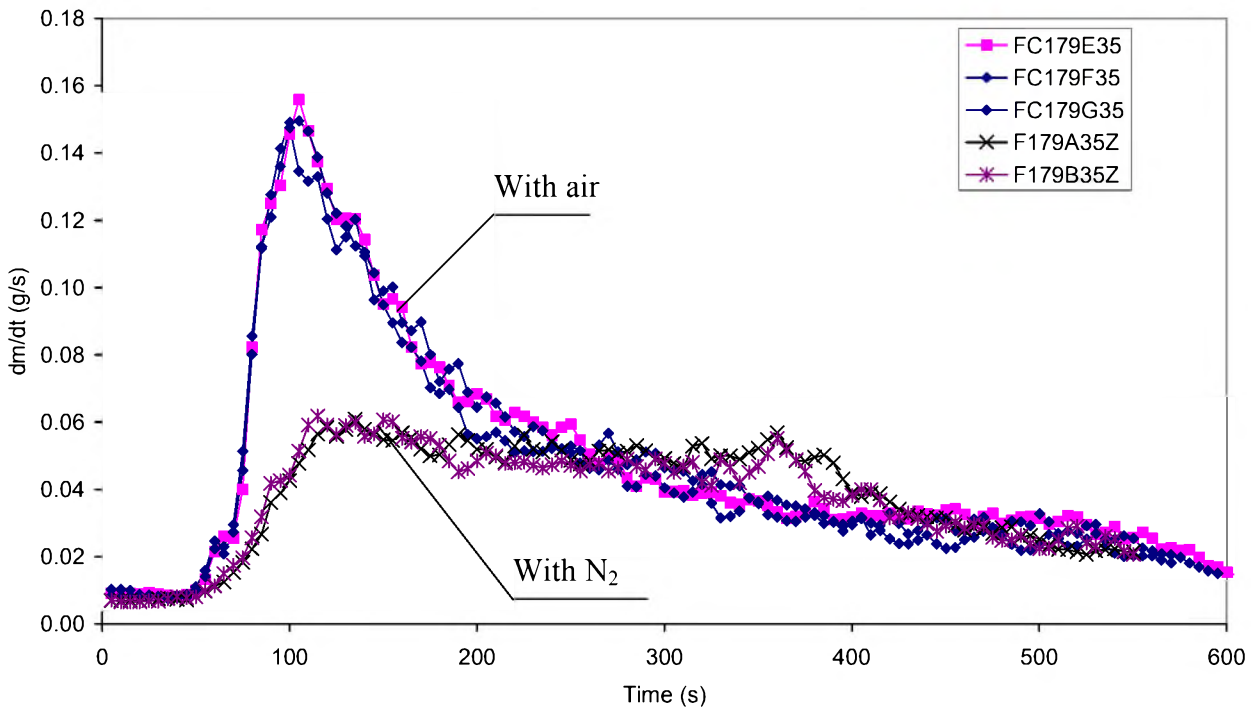

Specific extinction area v time

Cone RF1

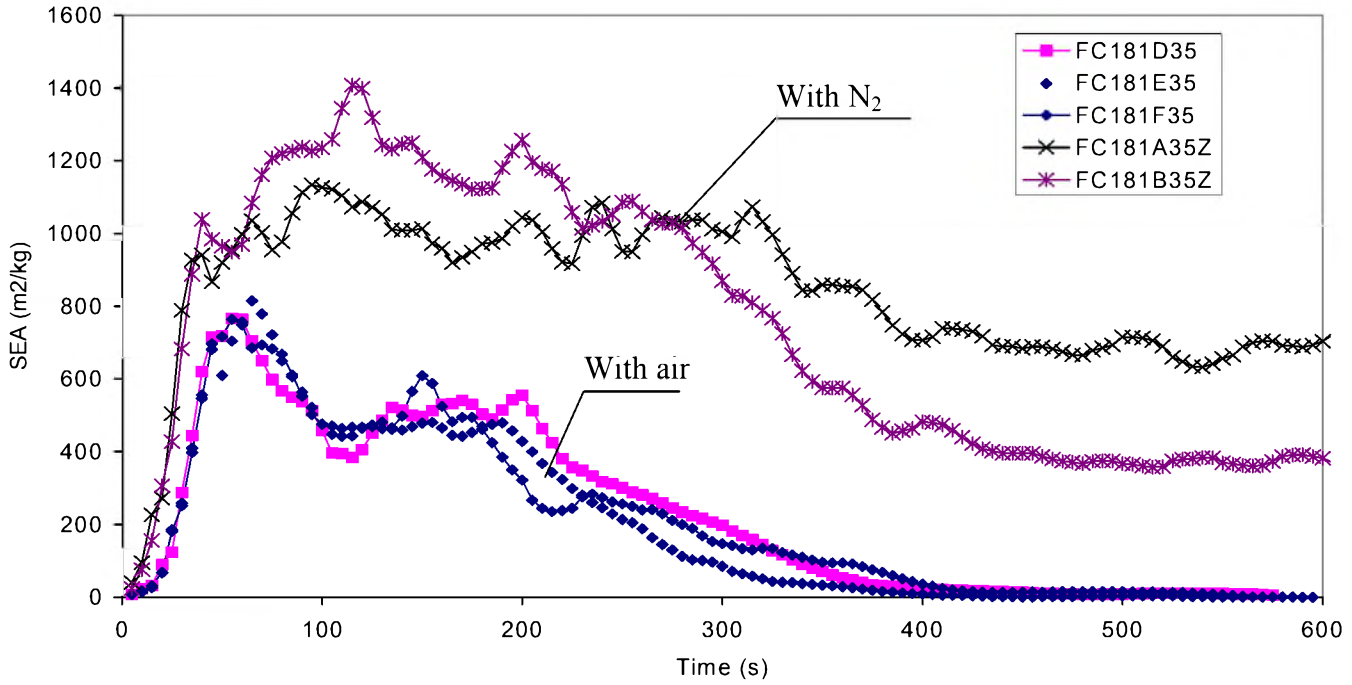

Specific extinction area v time

Cone W2B

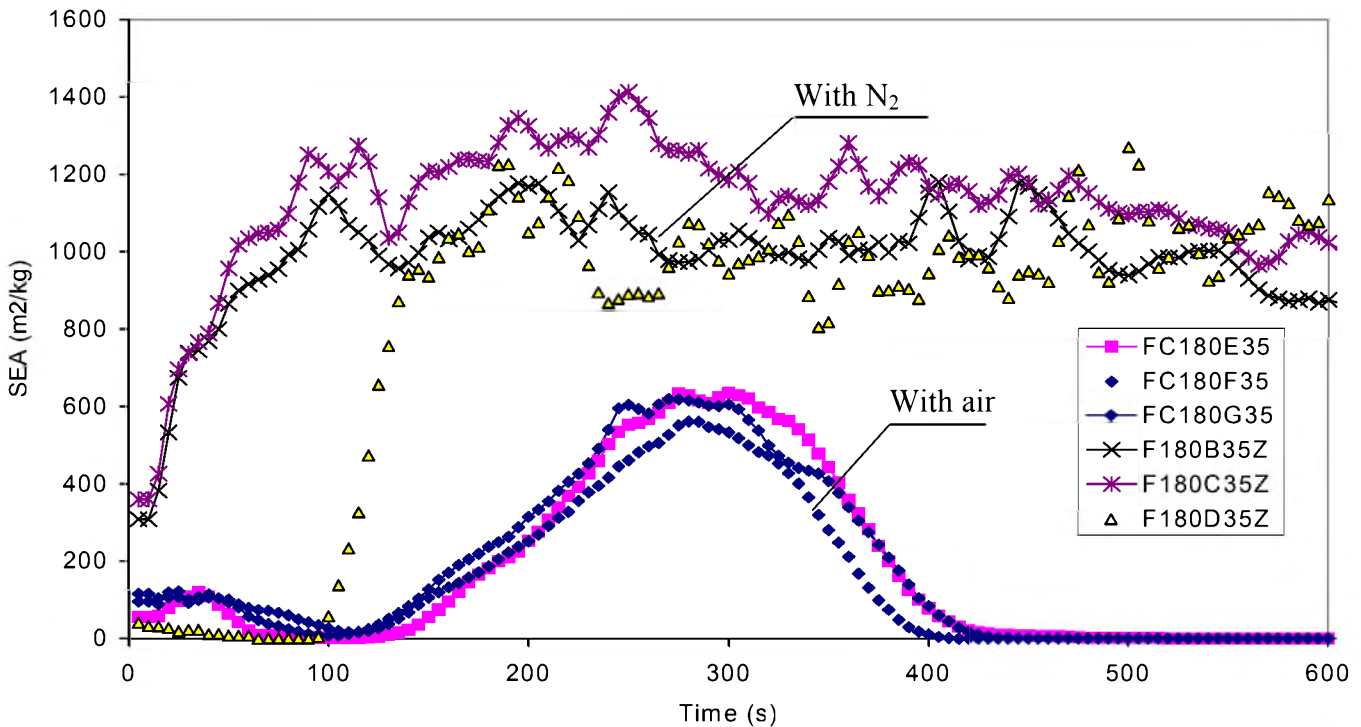

Specific extinction area v time

Cone N20

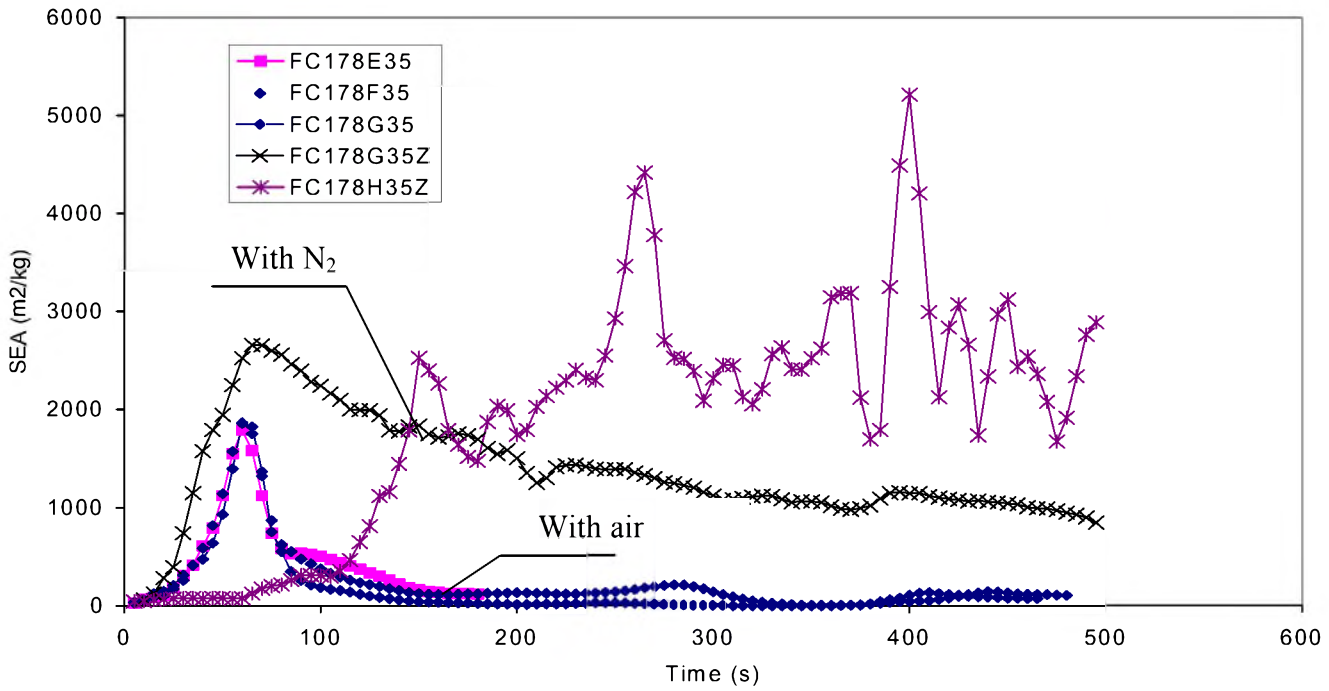

Specific extinction area v time

Cone N9

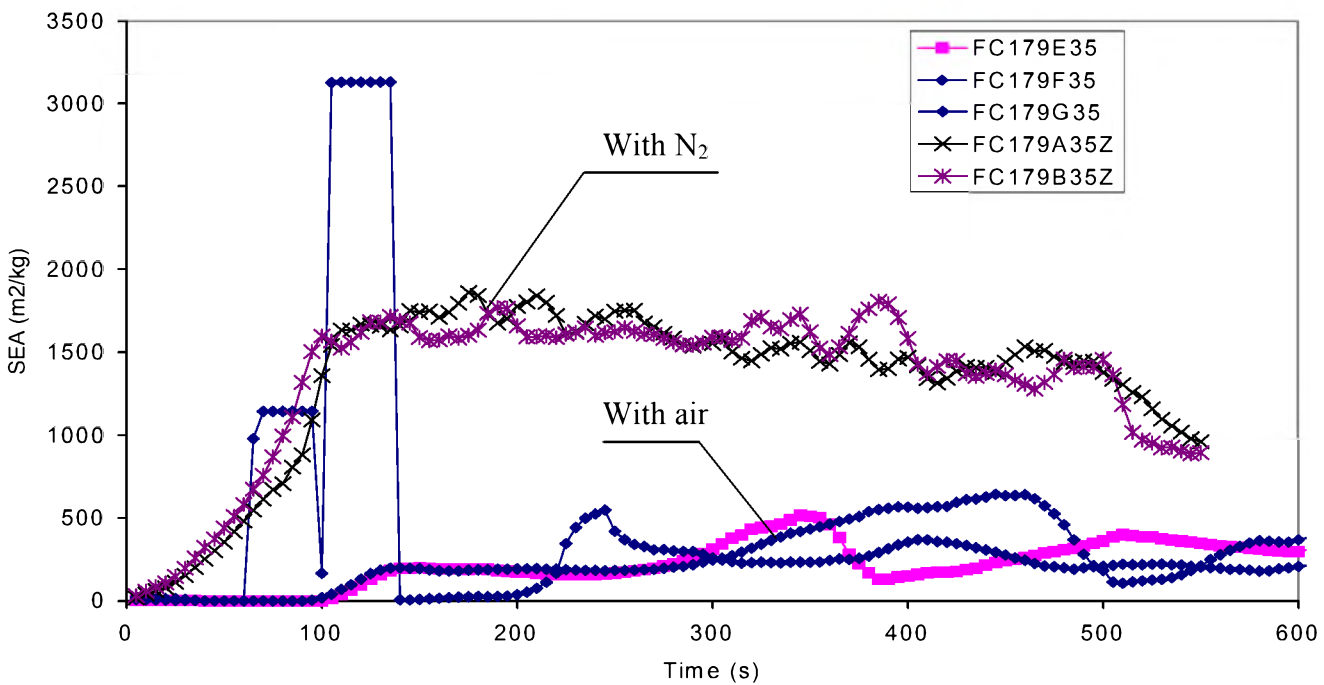

TEST METHODS

J1 Early Fire Hazard Test - AS 1530 Part 3

J.1.1. General

In this test a specimen of floor covering 600 x 450 mm is clamped in a vertical holder which faces a gas-fired radiant panel. The specimen holder is moved towards the radiant panel in a series of programmed steps over a period of 20 minutes, or until the specimen ignites, at which time the movement is stopped. Ignition is promoted by a gas pilot flame mounted 15 mm clear of the centre of the exposed face of the specimen, triggering the decomposition products rather than the specimen itself. If ignition occurs the radiation and smoke production of the specimen are monitored for 2 minutes (or more in certain cases). A general arrangement of the apparatus is shown in Appendix C.

The test results express fire behaviour under four headings in terms of separate numerical indices; these indices are interrelated, as they are obtained as a result of a single fire test.

J.1.2. Ignitability Index.

The Ignitability Index relates to the time taken for the volatiles from the test specimens, irradiated at increasing intensity, to form an ignitable gas mixture and be ignited by a small flame. The Index is zero if such ignition does not occur under the maximum impressed radiation during the test.

J.1.3. Spread of Flame Index.

The Spread of Flame Index relates to the rate of heat release by a burning material under impressed radiation that varies according to the time of ignition of the specimen. The scale of the Index is based on studies of actual rates of spread of flame on various wall-lining materials, in simulated corner wall situations. An Index of 10 indicates, from the original corner-burn experiments, that the material could be expected to cause flames to reach the ceiling of such a room within 10 s of ignition. An Index of zero means that the material will not cause flames to reach the ceiling within 4.5 minutes of ignition. Spread

of flame is measured indirectly only. What is actually measured is a rate of increase in radiation emitted by the specimen following ignition.

J.1.4. Heat Evolved Index.

This index relates to the amount of heat released by a burning material. Its linear scale allows distinctions to be drawn between materials on the basis of whether or not the amount of heat evolved from them would be likely to cause ignition of nearby combustibles. The higher the Index, the more likely is the fire involvement of nearby combustible materials.

J.1.5. Smoke Developed Index.

The Smoke Developed Index relates to the optical density of smoke produced under the conditions of the standard test. The higher the Index, the greater the hazard is likely to be from smoke. It should be noted that smoke measurements are made optically on a smoke column that is travelling at a velocity determined by the intensity of burning of the specimen. This velocity is neither controlled or measured, thus it is possible for a material burning slowly and giving off a moderate amount of smoke to obtain a similar record of smoke obscuration to that given by a material burning violently, with copious quantities of smoke. A further, more fundamental problem, related to both smoke and the other measurements is that the burning behaviour of different materials may be measured under widely differing radiant heat loads, according to the ignition propensity of the material under test.

J.2 Flooring Radiant Panel Test

The Flooring Radiant Panel Test (ASTM E648) is the test used to assess the fire performance of floor coverings in the USA and Canada. It also forms the basis of International Standard 9239.1–1997. A horizontally mounted floor covering specimen 1000 x 250 mm is subjected to radiation from a gas-fired radiant panel mounted above one end of the specimen and inclined at an angle of 30° to it. The specimen and the radiant panel are located within a test chamber. Air is allowed to flow in the bottom of the test chamber and exits via a stack at the top of the chamber, at the opposite end to the radiant panel. The general arrangement of the apparatus is shown in Appendix C.

A gas pilot flame is applied to the hotter end of the specimen. Following ignition, any flame front which develops is noted and a record is made of the progression of the flame front horizontally along the length of the specimen in terms of the time it takes to travel to various distances. The results are expressed in terms of flame spread distance versus time, the critical heat flux at extinguishment and the average heat for sustained burning.

The radiant flux profile along the specimen varies from 11 kW/m² immediately under the panel to approximately 1 kW/m² at the other end of the specimen. The Critical Radiant Flux (CRF) result equates to the minimum radiant energy a fire needs to sustain flame propagation in the flooring system. The lower the number, the greater is the tendency of the system to spread flame. In the USA, flooring systems are required to have a minimum critical radiant flux of 4.5 kW/m² if they are to be used in corridors and exitways of hospitals and nursing homes. For use in corridors and exitways of other occupancies (except one and two family dwellings) the minimum CRF value is 2.2 kW/m².

The Flooring Radiant Panel Test is different from most fire test methods in that it measures an actual property of the carpet system and is not based on an arbitrary scale. The test yields data correlated to the relative performance of materials in actual installations. It is not, however, without its detractors. There is a body of opinion that the applied radiation load is not sufficient to expose the performance of flooring systems in a fully developed fire. A figure of 25 kW/m² has been suggested as a more suitable maximum exposure level. Experience has shown that the single point pilot flame can cause problems with reproducibility of ignition, especially with materials which melt into a pool prior to ignition, as some nylon carpets tend to. This problem has been addressed by NIST and one of the modifications made when adapting this test method to an ISO Standard was to alter the pilot burner to a multi-point burner covering the full width of the specimen. Another change was to add a smoke meter in the exhaust stack to allow measurement of smoke production.

J.3 Cone Calorimeter

The Cone Calorimeter is a high technology small-scale fire test apparatus which draws the best attributes of a number of earlier fire tests into one integrated apparatus. Its design enables the measurement of rate of heat release; mass loss rates; ignitability; smoke density; and gas species concentration at various irradiance levels. Once a combustible material or product is ignited, its rate of heat release determines the speed of fire development and consequently the release of smoke and toxic gases. The Cone Calorimeter is a powerful instrument in this field and is subject to ASTM E 1354–97 and ISO 5660 testing standards.

The Cone Calorimeter consists of:

- a truncated conical radiant heater, internally wound with a sheathed electrical element capable of operating at up to 100 kW/m²;
- sample holders to hold sample of area 100 mm x 100 mm, up to 50 mm thick;
- weighing device to weigh to ±0.1 g, maximum load 500 g;
- exhaust gas system comprising hood and duct fitted with ring sampling gas port and soot sampling port, run at a set flow rate;
- gas train with facility to cool and dry exhaust gases and analyse carbon monoxide/dioxide, fitted with a high-accuracy oxygen analyser based on paramagnetic measurement of oxygen gas;
- helium–neon laser light sources with filters and detector system for smoke density measurement;
- a 5 kV spark ignition system (tests can be performed piloted or un-piloted) and
- data collection and analysis with PC-compatible hardware and software.

The key feature of the Cone Calorimeter is its ability to accurately measure heat release by the principle of oxygen consumption calorimetry. Whilst the heat release of fuels can vary widely per unit mass of fuel burnt, the heat release per unit mass of oxygen consumed is approximately constant for a wide range of materials. Hence measurement of the precise concentration of oxygen in the exhaust duct and the volumetric flow of exhaust gases gives the rate of oxygen consumption. From this, the rate of heat release

can be derived, without complications related to radiative and convective components of heat output. Appendix C shows principal components of the Cone Calorimeter.

A Dialog literature search was carried out to obtain information on applied radiation levels appropriate to the testing of floor coverings but little guidance was available. The levels chosen, on the basis of experience working with a broad range of materials in this laboratory, were 25, 35 and 50 kW/m².

J.4 CSIRO 10 Metre Fire Test Corridor

The 10 metre fire test corridor provides full-scale comparative testing between the performance of floor covering systems under the test scenario. The corridor is 10 metres long, 2.1 metres high and 1 metre wide, the minimum cross-sectional dimensions allowable for a corridor under the BCA. The attached fire room is 3.6 by 2.4 by 2.4 metres high, matching standard ASTM and ISO fire rooms.

The layout of the fire test room and corridor is shown in Figure 1. The corridor consists of eight modules, each 1.2 metres long, framed in galvanised steel and lined with 44 mm of ceramic fibreboard. The far end of the corridor terminates beneath a 3 metre by 3 metre square smoke collection hood connected to an exhaust fan and gas-fired afterburner, which removes harmful and visible emissions from the exhaust gases.

The fire load consists of the carpet under examination in the corridor, a wool carpet in the room and a Nordtest Standard (NT Fire 032) mock-up three-seat sofa in the room. The sofa is ignited with a match and within two minutes the room reaches flashover conditions, with sofa and carpet blazing strongly. This fire spreads to the carpet in the corridor, where flame travel along the test specimen is closely monitored. The fuel load was selected, after preliminary experiments, as being sufficient to spread flame on a wool carpet for some distance along the corridor, but not over the whole length of the corridor. This gives scope for the other carpets to demonstrate performance that is better, equivalent to or worse than that of the wool carpet.

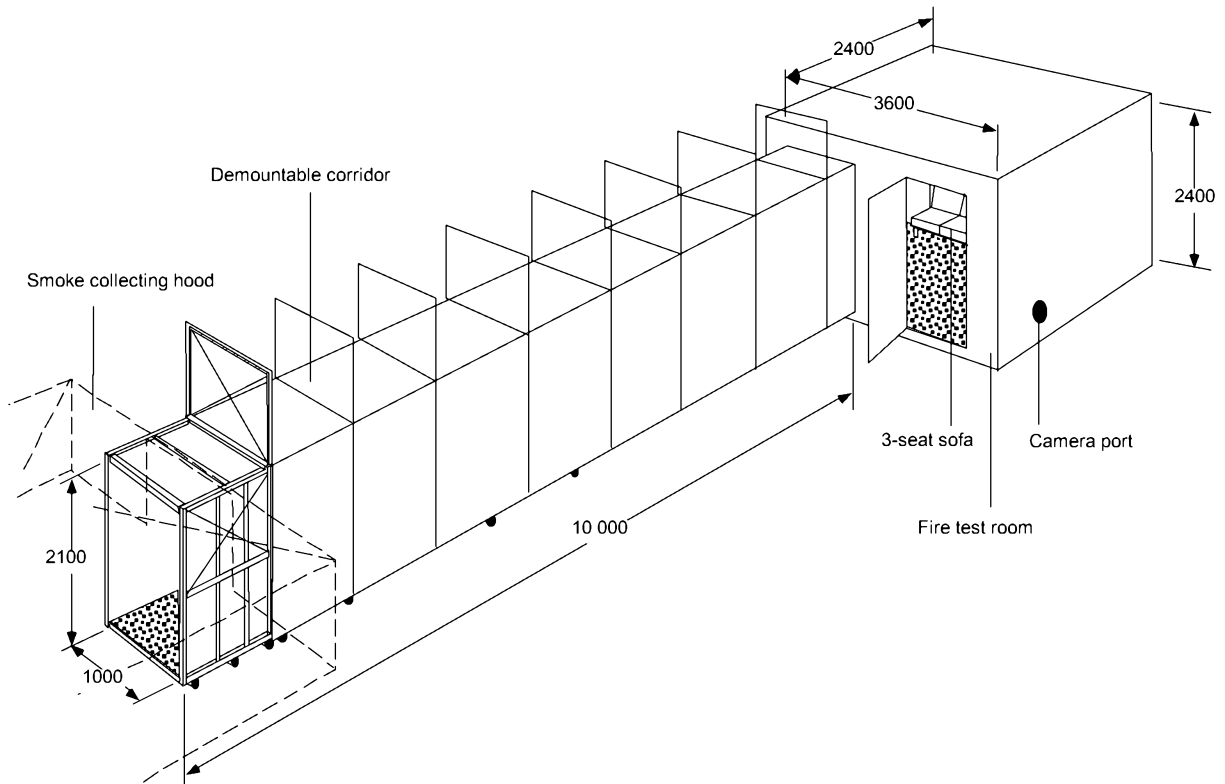

Figure 1. Layout of room/corridor fire test facility.

Thermocouples mounted along the length of the corridor measure the progress of flame travel. Heat release is measured by oxygen consumption calorimetry instrumentation mounted in the exhaust duct leading from the smoke collection hood. Flame spread behaviour in the corridor is recorded by a video camera mounted four metres clear of the open end of the corridor

The corridor test protocol is not a standard test method. Carpets are examined in one severe test scenario, with results in the form of behaviour comparisons, rather than absolute measurements.

Smoke characterisation in EFH and Cone Calorimeter for wall and ceiling linings and floor and floor covering materials

The objectives of this work are listed followed by the results:

- 1 *Collect available smoke related data for materials tested in*
 - (a) *the cone calorimeter; and*
 - (b) *the EFH*
- 2 *For each material, tabulate EFH Smoke Developed Index, Cone peak HRR x specific extinction area.*

Data was assembled from the following sources:

Project 2a Research Paper 7:

Tables 10, 11 (Results for wall and ceiling linings in the Cone Calorimeter); and
Table 13 (EFH results for wall and ceiling linings); and

Final Report on Fire Performance of Floors and Floor Coverings:

Appendix D (EFH results for floor coverings);
Appendix F (Cone Calorimeter results for floor coverings); and
Appendix G (Data from previous experiments on floor coverings).

The collected data and calculated values are given in the chart on Page 3 of this report.

- 3 *Where results are not available, calculate values by correlation.*

Where cone calorimeter results are not available, values of HRR x SEA have been interpolated or extrapolated from the plots of the known values. The plots and lines of best fit are shown in the charts on pages 4 and 5.

- 4 *Compare implications of change – current application in the BCA with proposed application (FCRC Projects 2A and 2B-1)*

The usage of the materials listed in Table 1 for floor, wall and ceiling linings in buildings using current and proposed test criteria is compared. The comparison addresses smoke controls alone. It does not consider the possibility of materials being prohibited because of their flame spread properties as determined by control of heat flux in the FRP or heat release rate in the Cone Calorimeter.

I FLOORS AND STAIRS:

Proposed control

We suggest that the value of Heat Release Rate x Specific Extinction Area in the Cone calorimeter (at 50 kW/m²) should be limited to 70,000 kW/kg (m²/kg x kW/ m²) where control is considered necessary.

The only (tested) flooring materials (including plywoods which were tested under Project 2A on wall and ceiling linings), that will be subject to restricted use under the proposed smoke controls are both polypropylene carpets (P6 and P14) and one nylon carpet (N14). Their potential to generate smoke means that these materials will not be allowed in fire isolated exits in any buildings, or anywhere in unsprinklered buildings.

Current controls

Under current BCA controls, smoke prohibits the use of all the tested materials except plasterboard in fire-isolated exits. Smoke controls do not restrict the use of the tested materials in any other areas, except:

- A in non-required, non-fire-isolated stairways and ramps (BCA Specification D1.12), where some vinyls, polypropylene carpet and nylon carpet are not allowed;
- B in patient-care areas in health care buildings where some vinyls, polypropylene carpet and nylon carpet are not allowed; and
- C in unsprinklered auditoria, where some vinyls, polypropylene carpet and nylon carpet are not allowed.

II WALLS AND CEILINGS:

Proposed controls

Fire spread on vertical surfaces is about 10 times as fast as fire spread on floors. Smoke production is similarly accelerated. We therefore suggest that, where smoke controls are recommended by Project 2A (see Table 2 of the Supplement to the Final Report for Project 2A), the Heat Release Rate x Specific Extinction Area in the Cone Calorimeter (at 50 kW/m²) should be limited to 7,000 kW/kg (m²/kg x kW/ m²).

With these controls, the only (tested) materials permitted in fire isolated exits, public corridors in Class 2 – 4, 9a and 9b buildings, patient care areas and unsprinklered auditoria are plasterboard and some plywoods. In all other areas there are no restrictions on the use of the tested products.

Current controls

Under current BCA controls, smoke prohibits the use of all the tested materials except plasterboard, some plywoods and GR phenolic (71b) in fire-isolated exits. In public corridors in Class 2 – 4, 9a and 9b buildings and walls in patient care areas and unsprinklered auditoria, the only prohibited product is polystyrene foam. Although controls on ceilings in patient care areas and unsprinklered auditoria are more strict, the only tested product that is prohibited is again polystyrene foam.

Peak Heat release Rate v Critical Radiant Flux

In addition on Pages 6 and 7 we include plots of Peak Heat Release Rate v Critical Radiant Flux at 35 kW/m² and 50 kW/m². It appears that there is no correlation between these values.

CSIRO Fire Science and Technology Laboratory

Material	EFH Test No	EFH Smoke Developed Index	Obscuration (1/m)	Peak HRR (kW/m ²)	Peak HRR	SEA	SEA	HRR*SEA	HRR*SEA
<i>Flooring (Project 2b-1)</i>				50kW/m ²	35kW/m ²	50kW/m ²	35kW/m ²	50kW/m ²	35kW/m ²
Wool carpet	W2b-1	4	0.1	386	278	133	104	51338	28912
Wool carpet	W2b-2	3	0.1	386	278	133	104	51338	28912
Vinyl	RF1-1	5	0.3		290		220	80000*	63800
Vinyl	RF1-2	6	0.5		290		220	115000*	63800
Polypropylene carpet	P14-1	5	0.4	510	303	184	184	93840	55752
Polypropylene carpet	P14-2	6	0.55	510	303	184	184	93840	55752
Nylon carpet	N20-1	7	0.55		490		350	200000*	171500
Nylon carpet	N20-2	7	0.6		490		350	200000*	171500
Nylon carpet	N20-3	7	0.8		490		350	200000*	171500
Nylon carpet	N20-4	7	0.7		490		350	200000*	171500
Wool carpet	W5	4		348	268	143	100	49764	26800
Polypropylene carpet	P6	4		447	291	210	210	93870	61110
Nylon carpet	N9	4		580	423	109	131	63220	55413
Nylon carpet	N13	5		483	335	133	139	64239	46565
Nylon carpet	N14	4		485	403	169	192	81965	77376
<i>Wall and ceiling (Project 2a)</i>									
GR Phenolic 70	A01	3	0.03	106		222		23532	26000*
GR Phenolic 71b	A02	2	0.02	88		141		12408	13000*
Plasterboard US	A03	1	0.01	119		17		2023	4000*
Plywood FR US	A04	3	0.06	121		12		1452	26000*
Plywood US	A05	2	0.02	218		52		11336	13000*
Polyurethane Foam US	A06	3	0.04	86		363		31218	26000*
Polystyrene Foam US	A07	5	0.22	509		1281		652029	650000*
Hardboard	A08	3	0.033	458		44		20152	26000*
Plasterboard,	A09	1	0.011	107	102	23	45	2461	4590
Plywood,	A10	3	0.037	426	291	67	70	28542	20370
Plywood FR	A11	3	0.045	317	294	59	60	18703	17640

* - interpolated or extrapolated values

HRRxSEA (at 50 kW/m²) v Smoke Developed Index

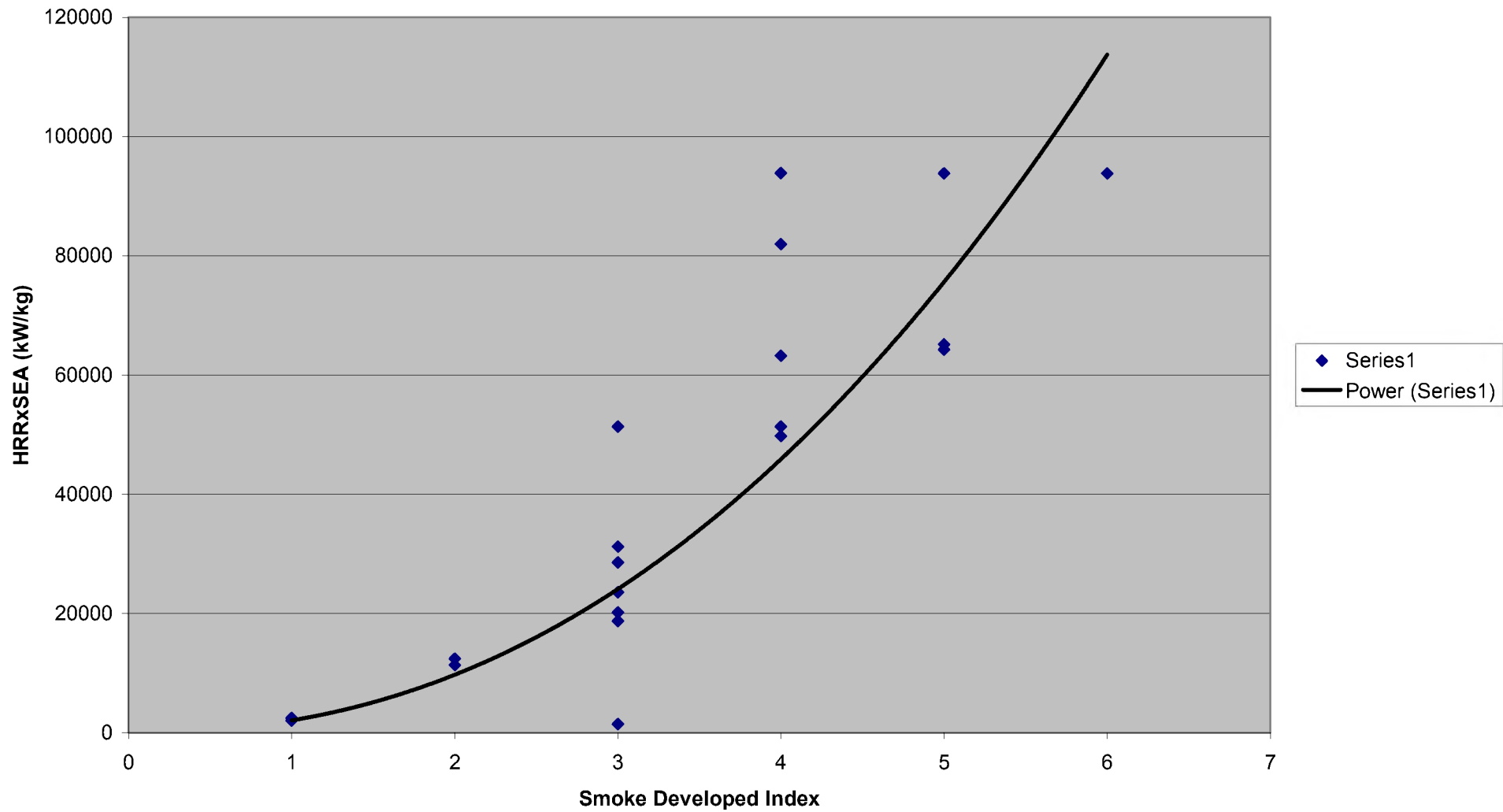

HRRxSEA (at 35kW/m²) v Smoke Developed Index

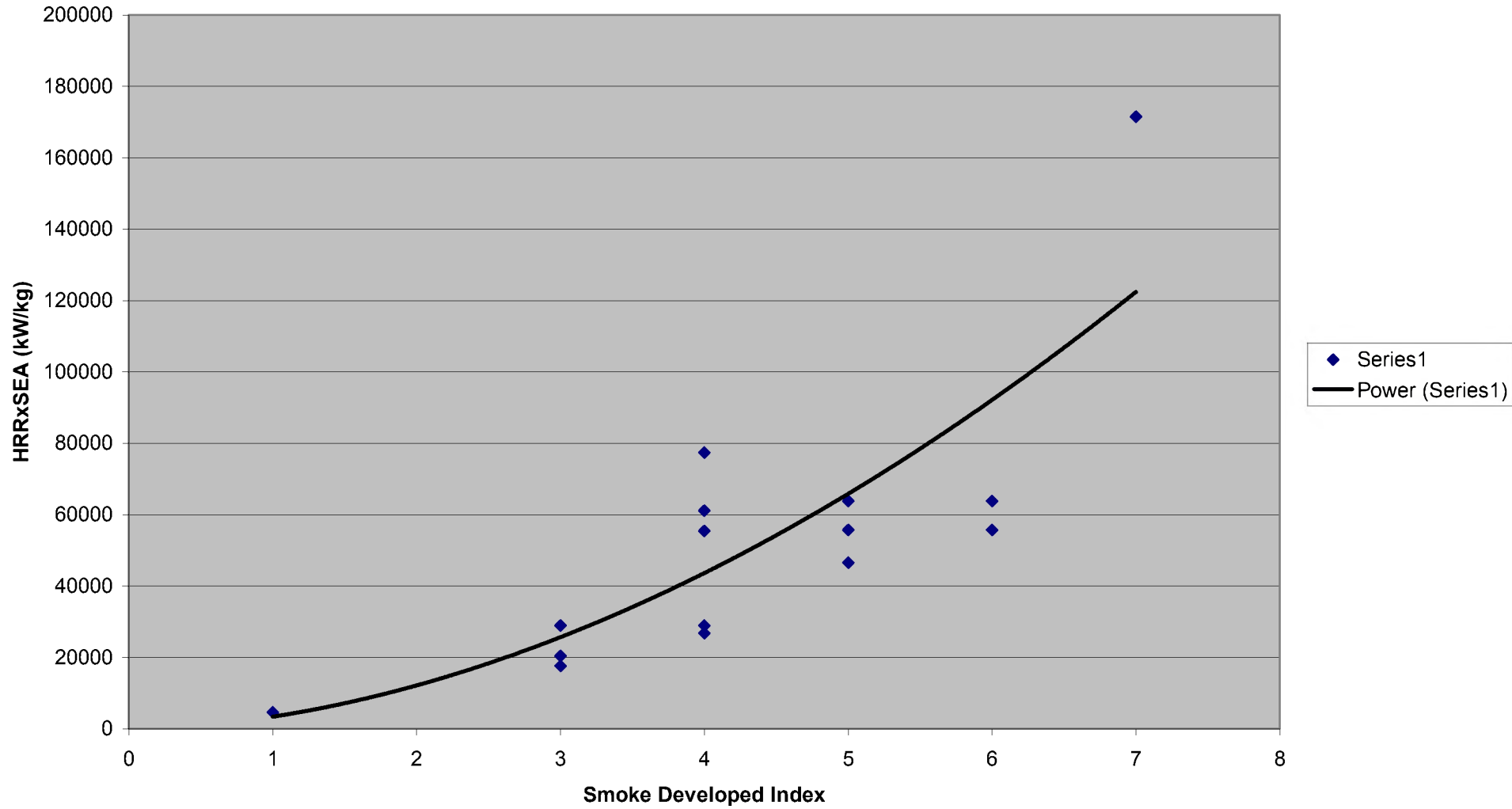

Peak HRR at 35 kW/m² v Critical Radiant Flux

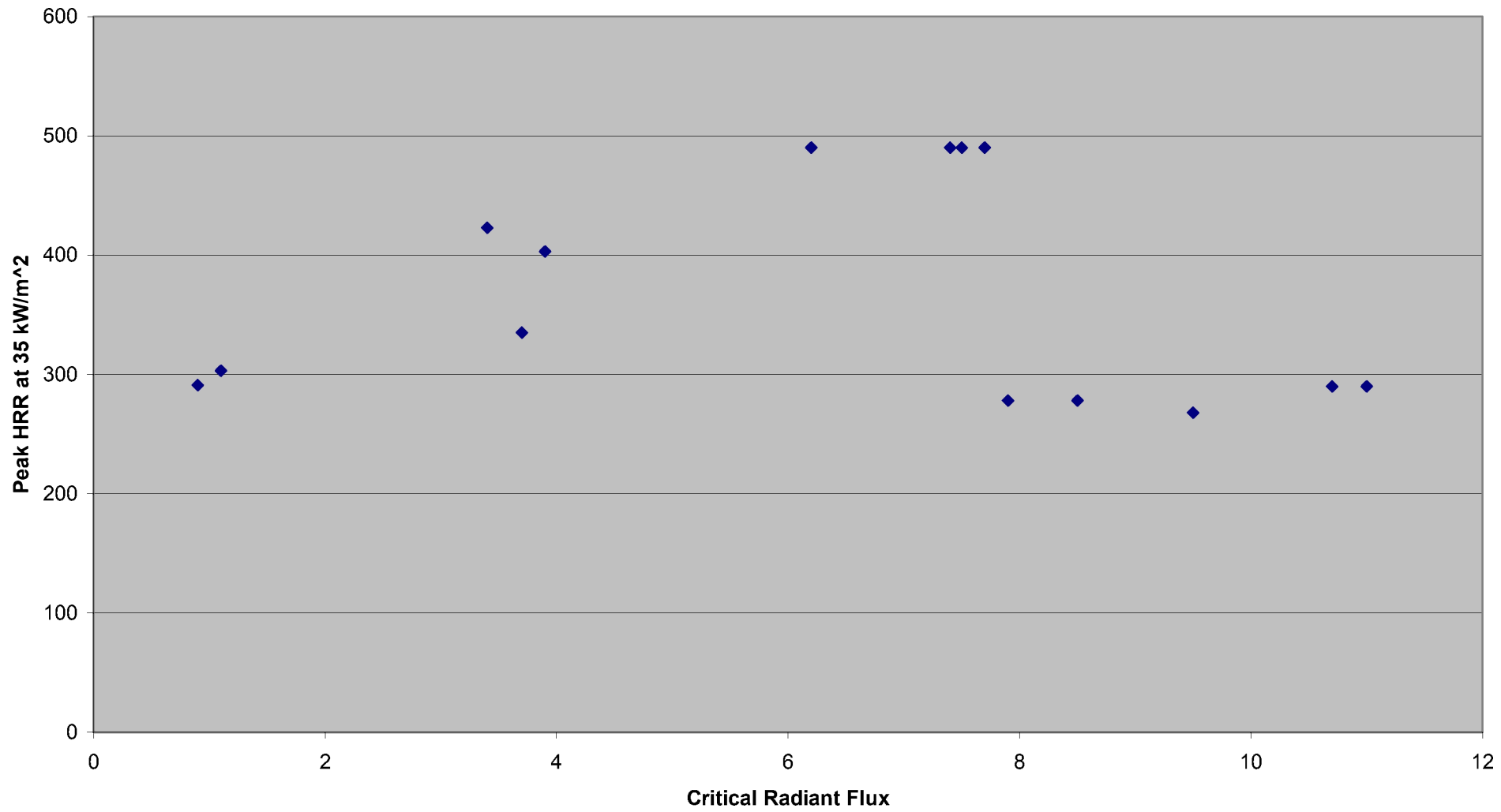

Peak HRR at 50kW/m² v Critical Radiant Flux

